

IP datagram format

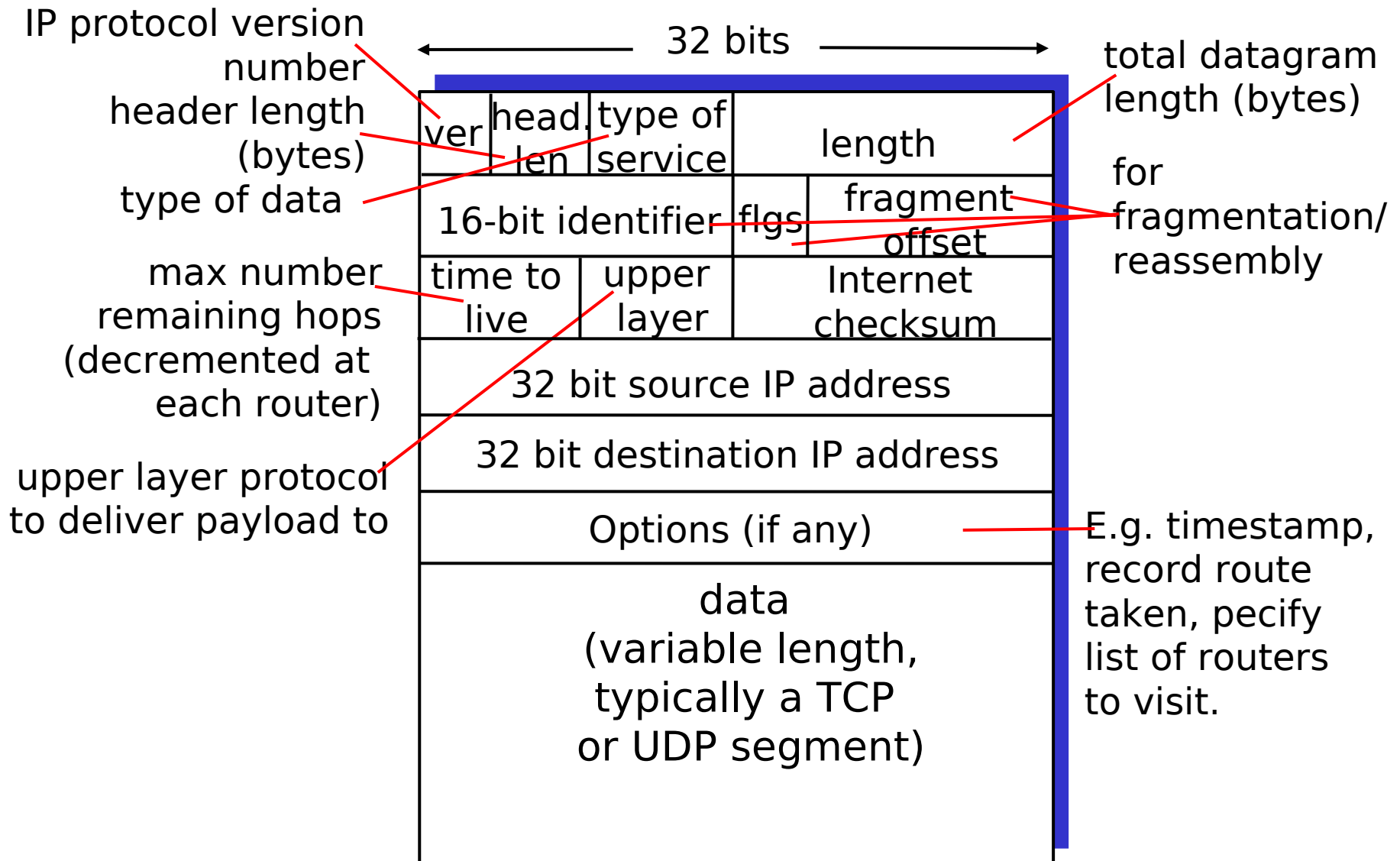

IP Fragmentation & Reassembly

- network links have MTU (max.transfer size) - largest possible link-level frame.
 - different link types, different MTUs
- large IP datagram divided (fragmented) within net
 - one datagram becomes several datagrams
 - reassembled only at final destination
 - IP header bits used to identify, order related fragments

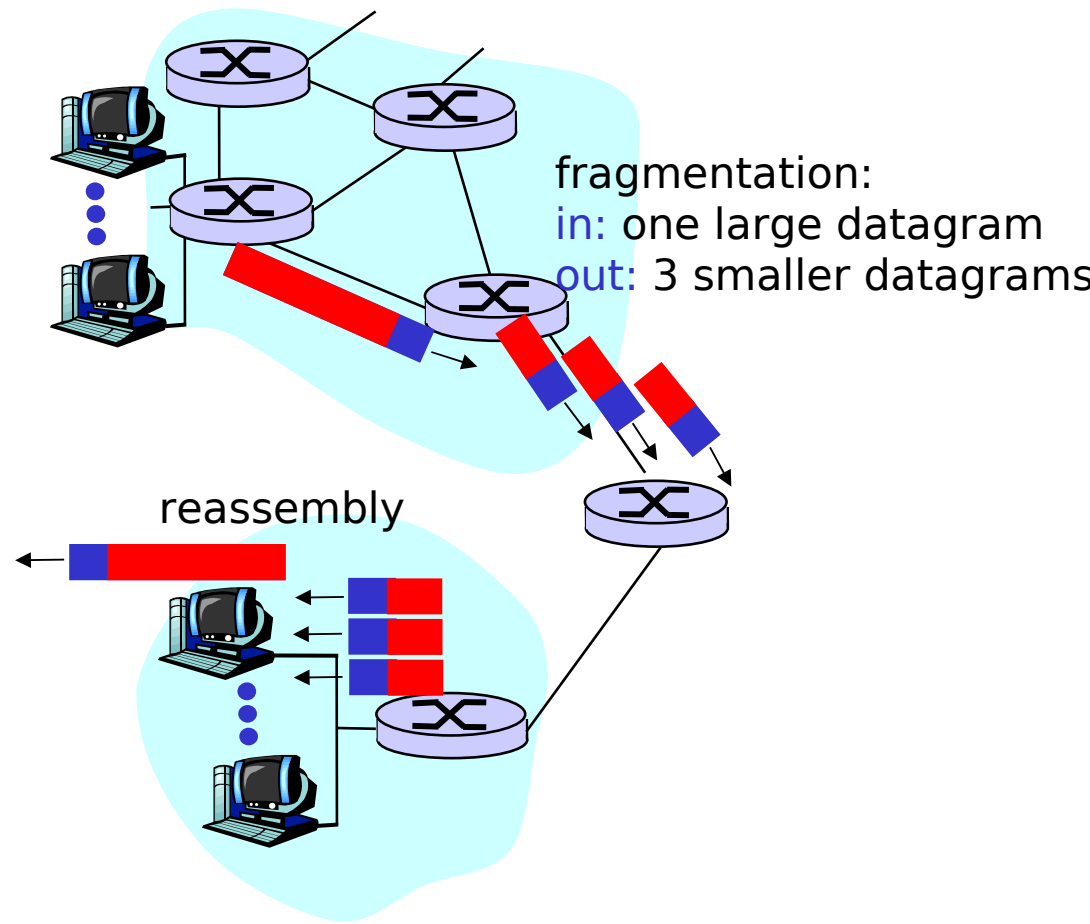

IP Fragmentation and Reassembly

length	ID	fragflag	offset
=4000	=x	=0	=0

One large datagram becomes several smaller datagrams

length	ID	fragflag	offset
=1500	=x	=1	=0

length	ID	fragflag	offset
=1500	=x	=1	=1480

length	ID	fragflag	offset
=1040	=x	=0	=2960

ICMP: Internet Control Message Protocol

- used by hosts, routers, gateways to communication network-level information
 - error reporting: unreachable host, network, port, protocol
 - echo request/reply (used by ping)
- network-layer above IP:
 - ICMP msgs carried in IP datagrams
- **ICMP message:** type, code plus first 8 bytes of IP datagram causing error

<u>Type</u>	<u>Code</u>	<u>description</u>
0	0	echo reply (ping)
3	0	dest. network unreachable
3	1	dest host unreachable
3	2	dest protocol unreachable
3	3	dest port unreachable
3	6	dest network unknown
3	7	dest host unknown
4	0	source quench (congestion control - not used)
8	0	echo request (ping)
9	0	route advertisement
10	0	router discovery
11	0	TTL expired
12	0	bad IP header

Routing in the Internet

- The Global Internet consists of **Autonomous Systems (AS)** interconnected with each other:
 - **Stub AS**: small corporation
 - **Multihomed AS**: large corporation (no transit)
 - **Transit AS**: provider

- Two-level routing:
 - **Intra-AS**: administrator is responsible for choice
 - **Inter-AS**: unique standard

Internet AS Hierarchy

AS border (exterior gateway) routers

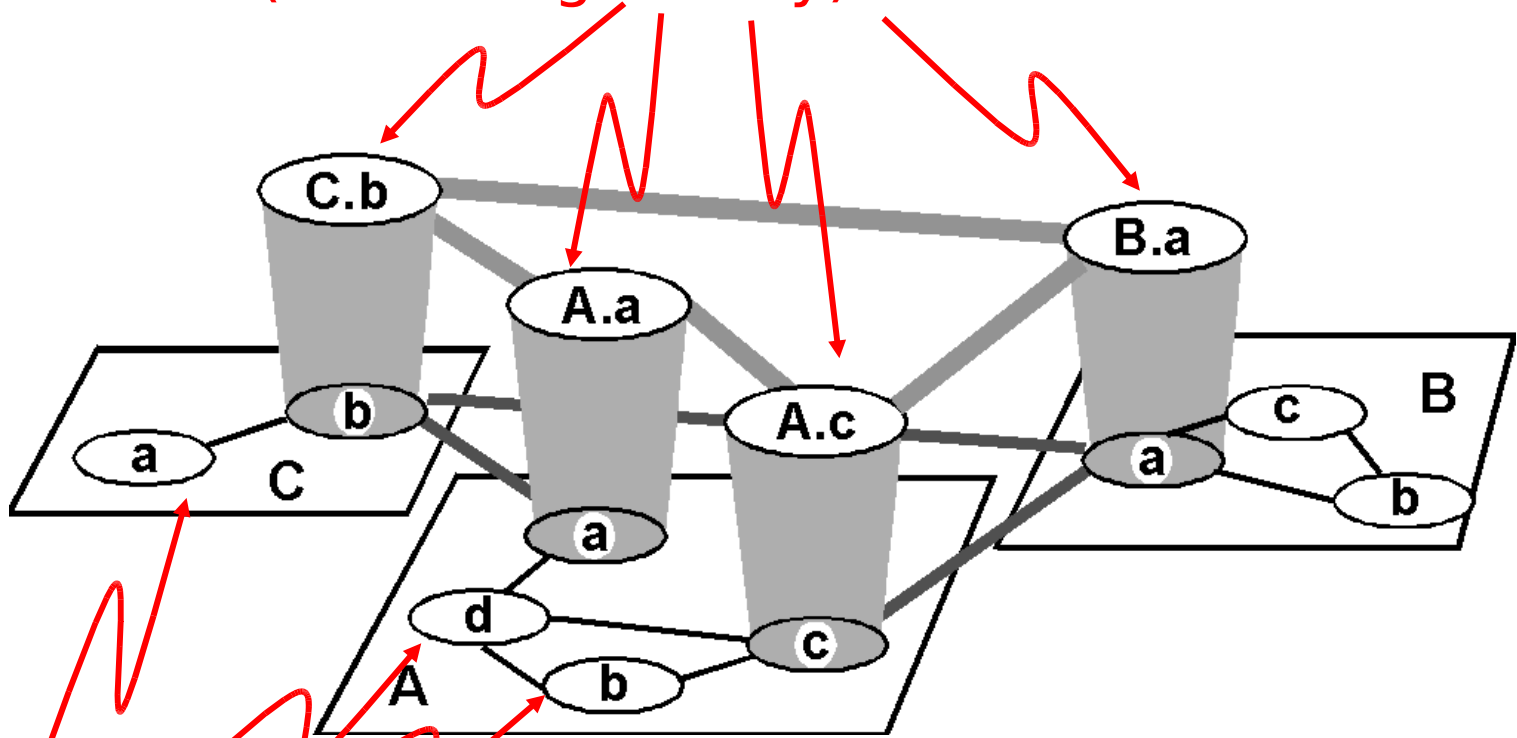

AS interior (gateway) routers

Intra-AS Routing

- ❑ Also known as **Interior Gateway Protocols (IGP)**
- ❑ Most common IGPs:
 - RIP: Routing Information Protocol
 - OSPF: Open Shortest Path First
 - IGRP: Interior Gateway Routing Protocol (Cisco propr.)

RIP (Routing Information Protocol)

- ❑ Distance vector algorithm
- ❑ Included in BSD-UNIX Distribution in 1982
- ❑ Distance metric: # of hops (max = 15 hops)
 - *Can you guess why?*
- ❑ Distance vectors: exchanged every 30 sec via Response Message (also called **advertisement**)
- ❑ Each advertisement: route to up to 25 destination nets

RIP (Routing Information Protocol)

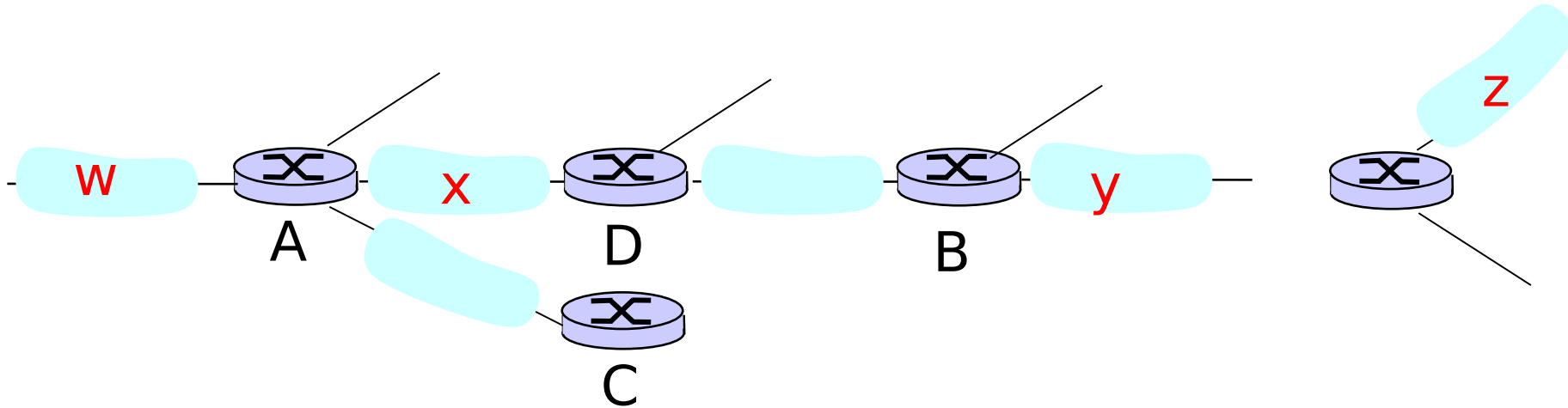

Destination Network to dest.	Next Router	Num. of hops
W	A	2
y	B	2
z	B	7
x	--	1

...

Routing table in D

....

RIP: Link Failure and Recovery

If no advertisement heard after 180 sec -->
neighbor/link declared dead

- routes via neighbor invalidated
- new advertisements sent to neighbors
- neighbors in turn send out new advertisements (if tables changed)
- link failure info quickly propagates to entire net
- poison reverse used to prevent ping-pong loops (infinite distance = 16 hops)

RIP Table_processing

- ❑ RIP routing tables managed by **application-level** process called route-d (daemon)
- ❑ advertisements sent in UDP packets, periodically repeated

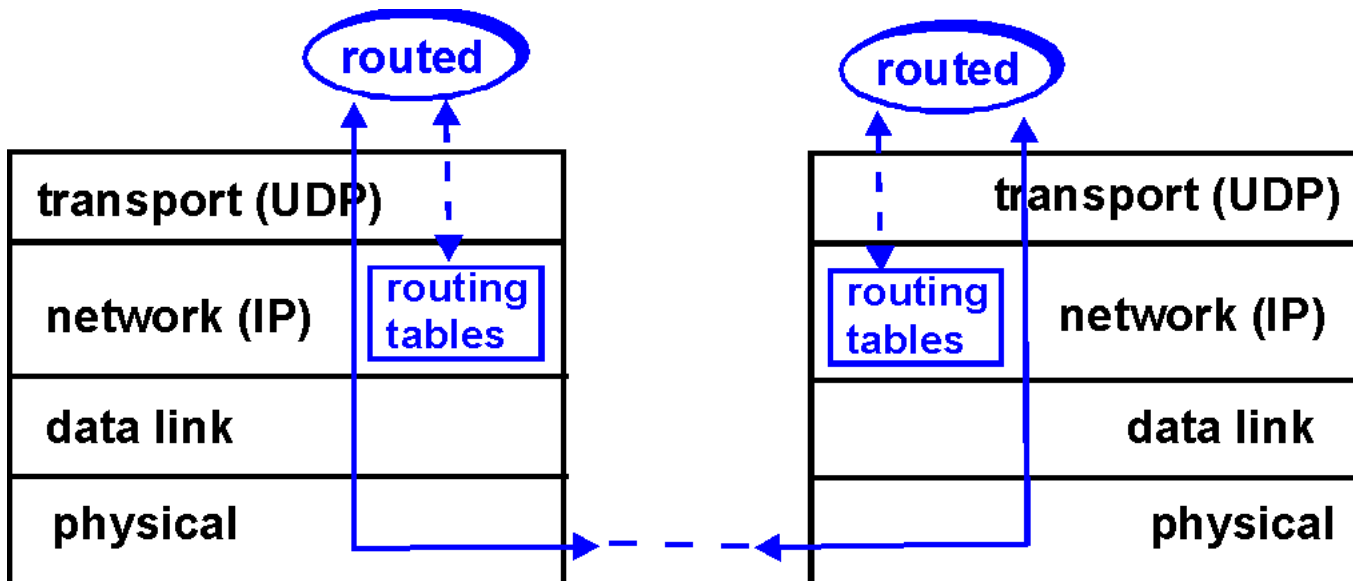

RIP Table example (continued)

Router: *girofflee.eurocom.fr*

Destination	Gateway	Flags	Ref	Use	Interface
127.0.0.1	127.0.0.1	UH	0	26492	lo0
192.168.2.	192.168.2.5	U	2	13	fa0
193.55.114.	193.55.114.6	U	3	58503	le0
192.168.3.	192.168.3.5	U	2	25	qaa0
224.0.0.0	193.55.114.6	U	3	0	le0
default	193.55.114.129	UG	0	143454	

- ❑ Three attached class C networks (LANs)
- ❑ Router only knows routes to attached LANs
- ❑ Default router used to go up
- ❑ Route multicast address: 224.0.0.0
- ❑ Loopback interface (for debugging)

OSPF (Open Shortest Path First)

- ❑ open: publicly available
- ❑ Uses Link State algorithm
 - LS packet dissemination
 - Topology map at each node
 - Route computation using Dijkstra's algorithm
- ❑ OSPF advertisement carries one entry per neighbor router
- ❑ Advertisements disseminated to **entire** AS (via flooding)

OSPF advanced features (not in RIP)

- ❑ **Security:** all OSPF messages authenticated (to prevent malicious intrusion); TCP connections used
- ❑ **Multiple** same-cost **paths** allowed (only one path in RIP)
- ❑ For each link, multiple cost metrics for different **TOS** (eg., satellite link cost set low for best effort; high for real time)
- ❑ Integrated uni- and **multicast** support:
 - Multicast OSPF (MOSPF) uses same topology data base as OSPF
- ❑ **Hierarchical** OSPF in large domains.

Hierarchical OSPF

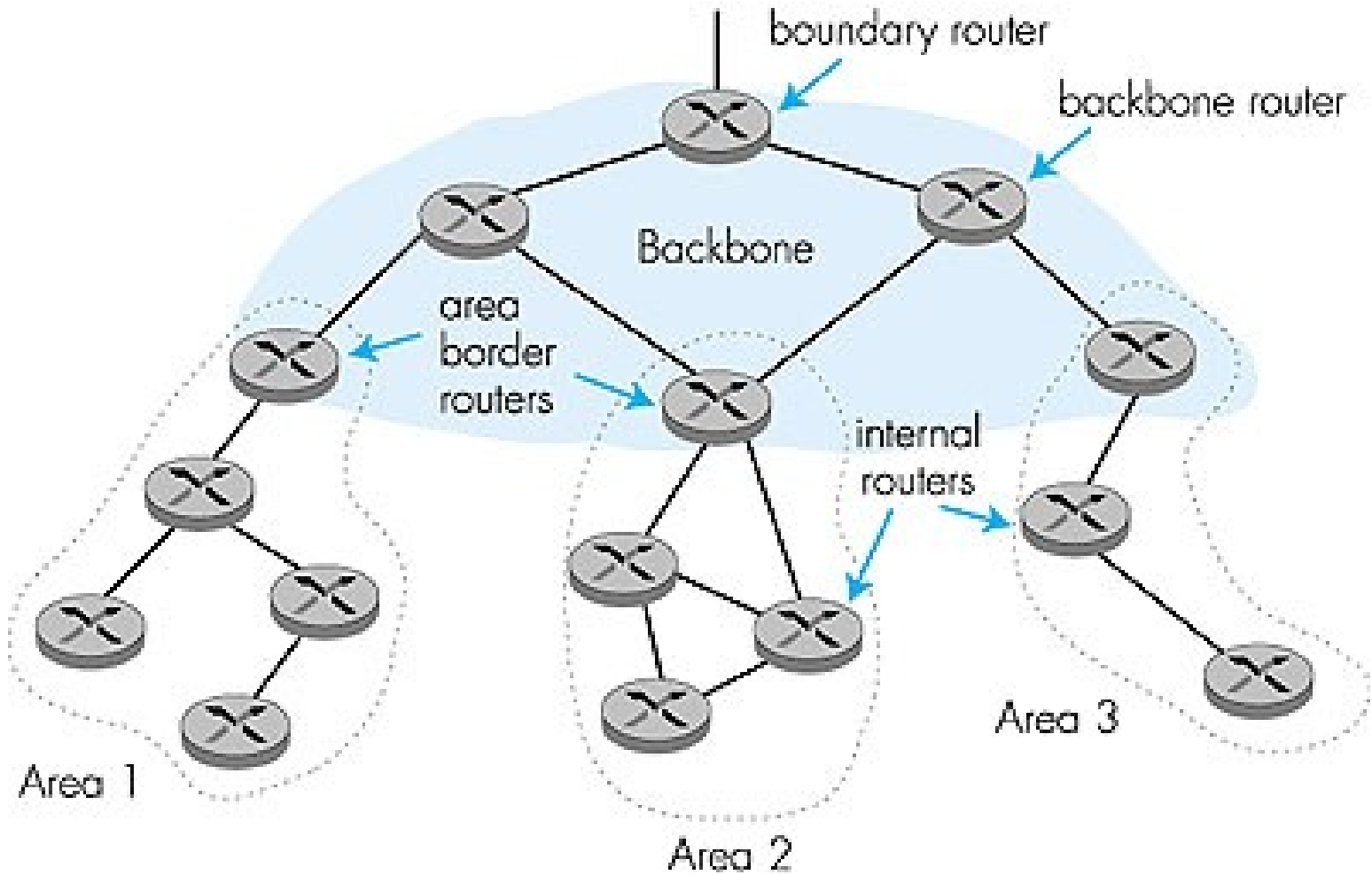

Hierarchical OSPF

- ❑ **Two-level hierarchy:** local area, backbone.
 - Link-state advertisements only in area
 - each nodes has detailed area topology; only know direction (shortest path) to nets in other areas.
- ❑ **Area border routers:** summarize distances to nets in own area, advertise to other Area Border routers.
- ❑ **Backbone routers:** run OSPF routing limited to backbone.
- ❑ **Boundary routers:** connect to other ASs.

IGRP (Interior Gateway Routing Protocol)

- ❑ CISCO proprietary; successor of RIP (mid 80s)
- ❑ Distance Vector, like RIP
- ❑ several cost metrics (delay, bandwidth, reliability, load etc)
- ❑ uses TCP to exchange routing updates
- ❑ Loop-free routing via Distributed Updating Alg. (DUAL) based on *diffused computation*

Router Architecture Overview

Two key router functions:

- run routing algorithms/protocol (RIP, OSPF, BGP)
- *switching* datagrams from incoming to outgoing link

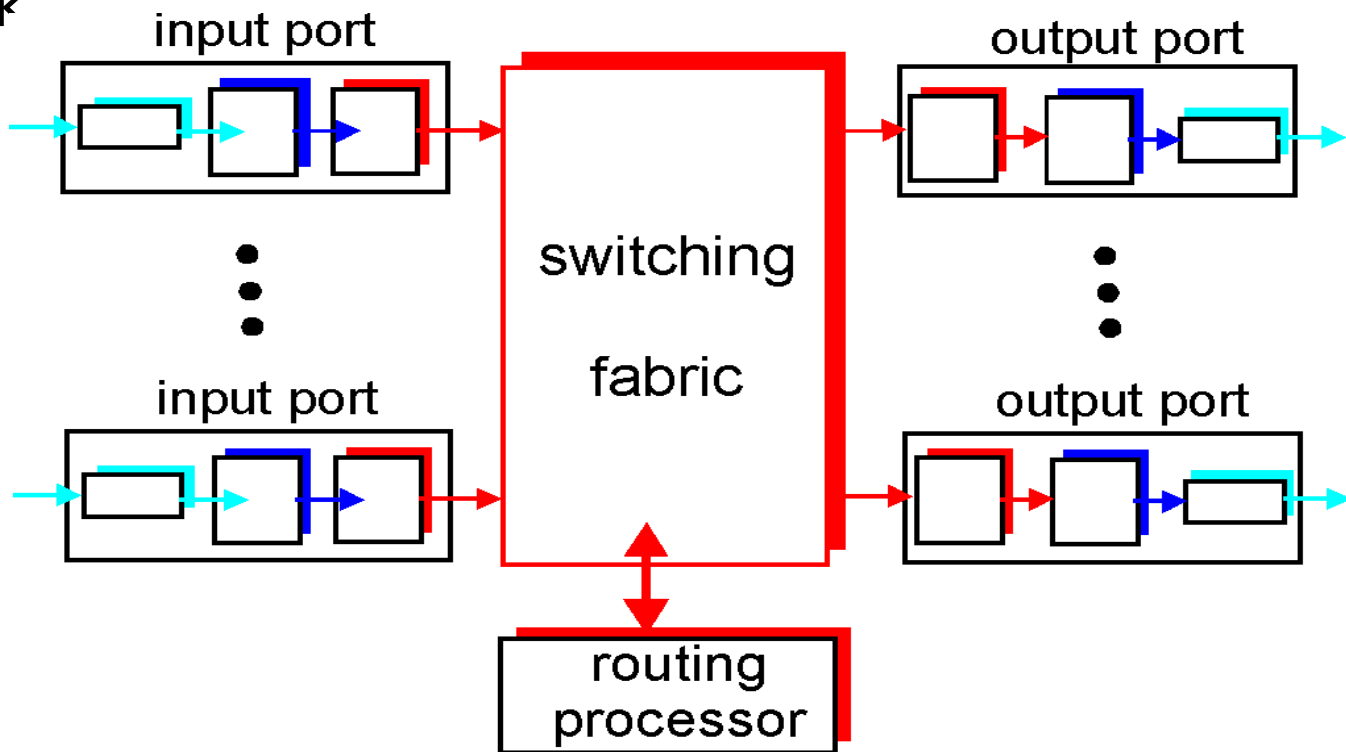

Input Port Functions

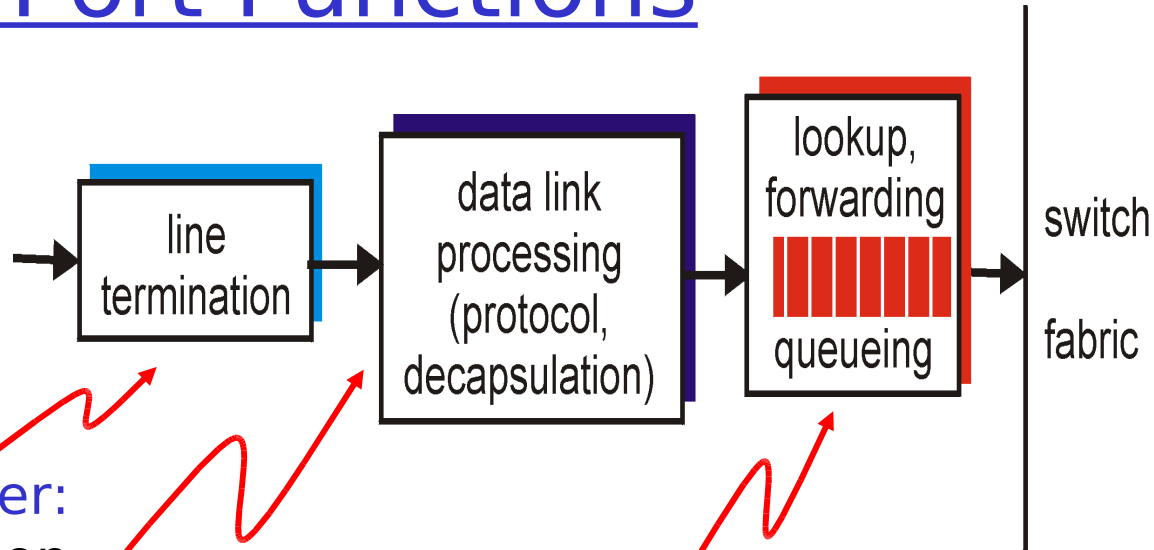

Physical layer:
bit-level reception

Data link layer:
e.g., Ethernet
see chapter 5

Decentralized switching:

- ❑ given datagram dest., lookup output port using routing table in input port memory
- ❑ goal: complete input port processing at 'line speed'
- ❑ queuing: if datagrams arrive faster than forwarding rate into switch fabric

Input Port Queuing

- ❑ Fabric slower than input ports combined -> queuing may occur at input queues
- ❑ **Head-of-the-Line (HOL) blocking:** queued datagram at front of queue prevents others in queue from moving forward
- ❑ *queuing delay and loss due to input buffer overflow*

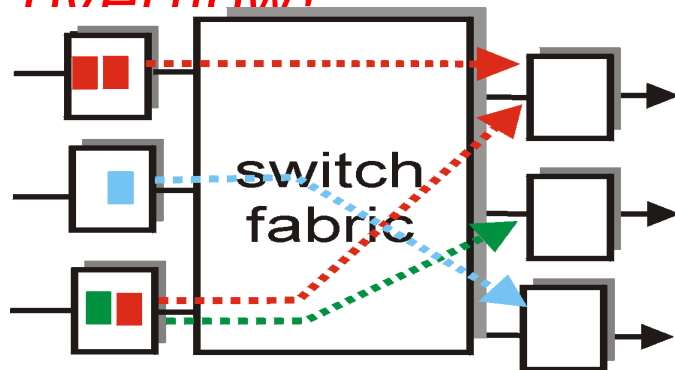

output port contention
at time t - only one red
packet can be transferred

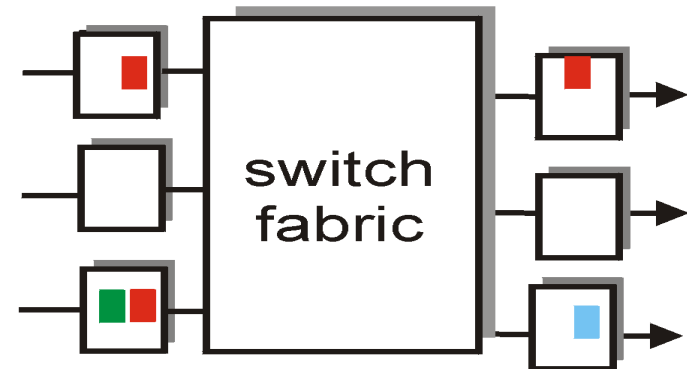

green packet
experiences HOL blocking

Three types of switching fabrics

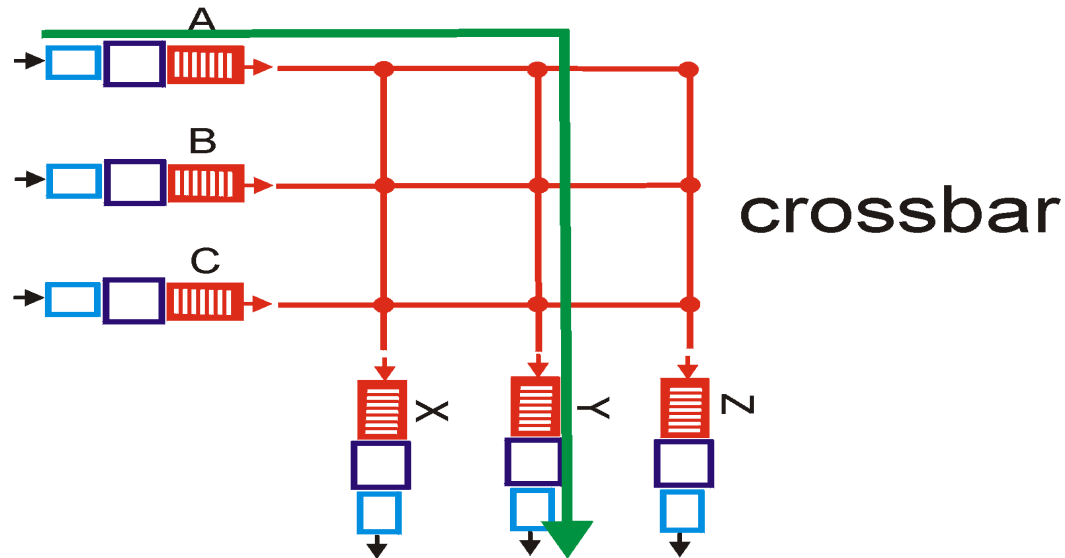
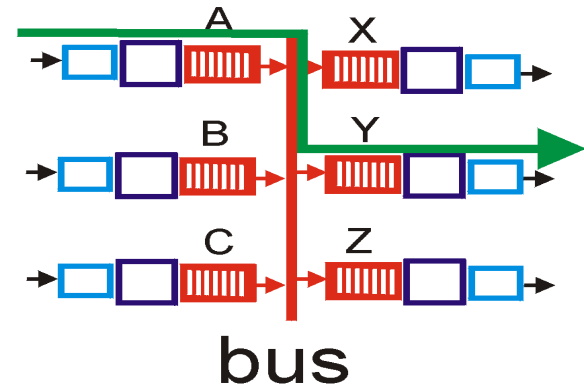
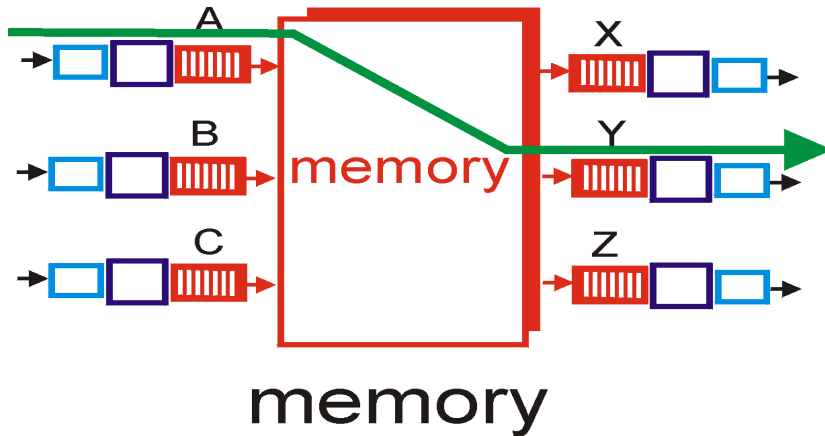

Switching Via Memory

First generation routers:

- ❑ packet copied by system's (single) CPU
- ❑ speed limited by memory bandwidth (2 bus crossings per datagram)

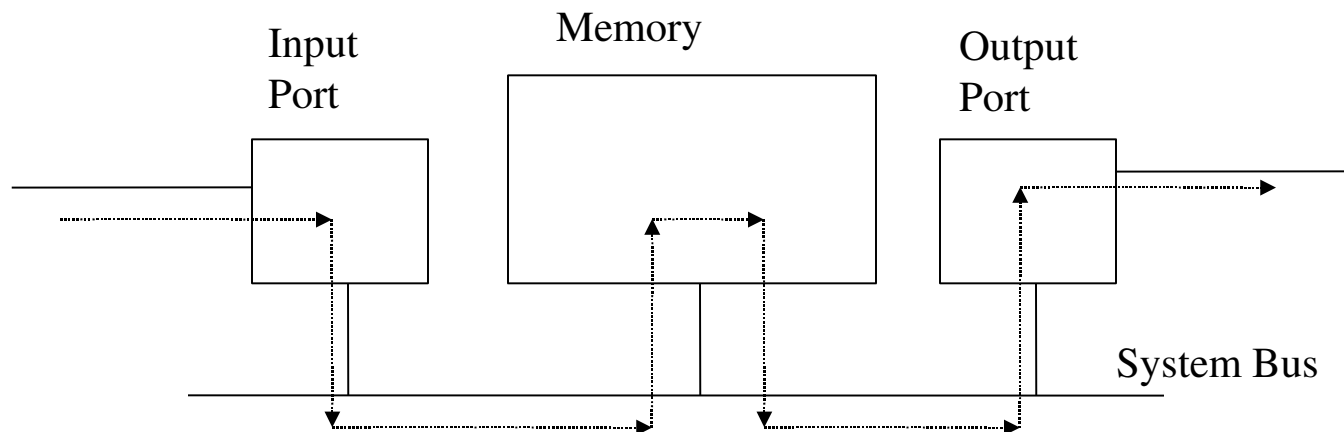

Modern routers:

- ❑ input port processor performs lookup, copy into memory
- ❑ Cisco Catalyst 8500

Switching Via Bus

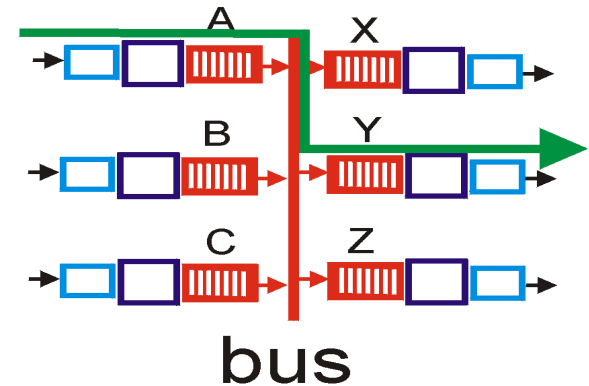

- ❑ datagram from input port memory to output port memory via a shared bus
- ❑ **bus contention:** switching speed limited by bus bandwidth
- ❑ 1 Gbps bus, Cisco 1900: sufficient speed for access and enterprise routers (not regional or backbone)

Switching Via An Interconnection Network

- ❑ overcome bus bandwidth limitations
- ❑ Banyan networks, other interconnection nets initially developed to connect processors in multiprocessor
- ❑ Advanced design: fragmenting datagram into fixed length cells, switch cells through the fabric.
- ❑ Cisco 12000: switches Gbps through the interconnection network

Output Ports

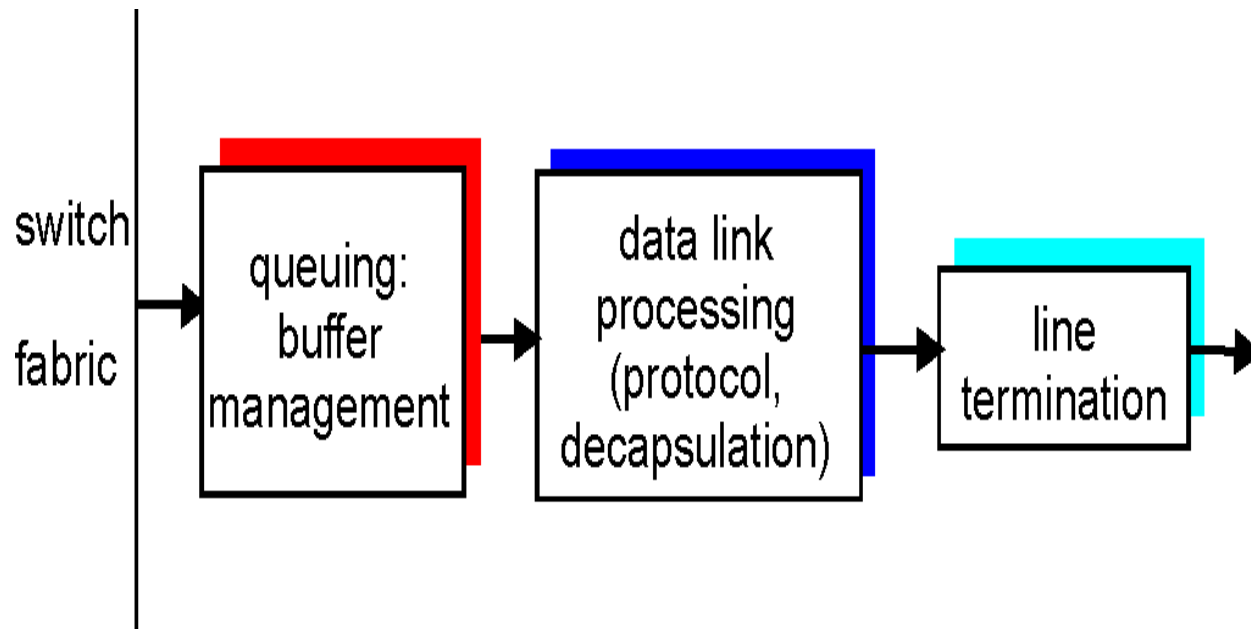

- ❑ **Buffering** required when datagrams arrive from fabric faster than the transmission rate
- ❑ **Scheduling discipline** chooses among queued datagrams for transmission

Output port queueing

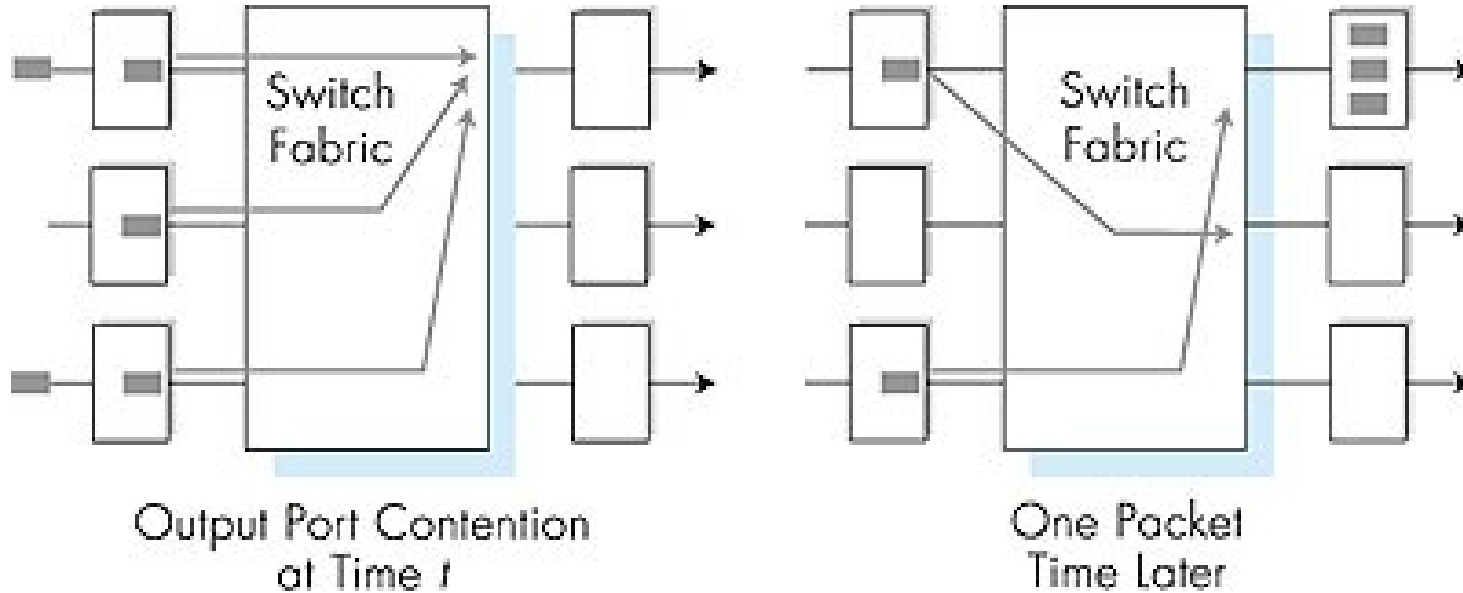

- buffering when arrival rate via switch exceeds output line speed
- *queueing (delay) and loss due to output port buffer overflow!*

IPv6

- ❑ **Initial motivation:** 32-bit address space completely allocated by 2008.
- ❑ **Additional motivation:**
 - header format helps speed processing/forwarding
 - header changes to facilitate QoS
 - new anycast address: route to best of several replicated servers
- ❑ **IPv6 datagram format:**
 - fixed-length 40 byte header
 - no fragmentation allowed

IPv6 Header (Cont)

Priority: identify priority among datagrams in flow

Flow Label: identify datagrams in same flow.
(concept of flow not well defined).

Next header: identify upper layer protocol for data

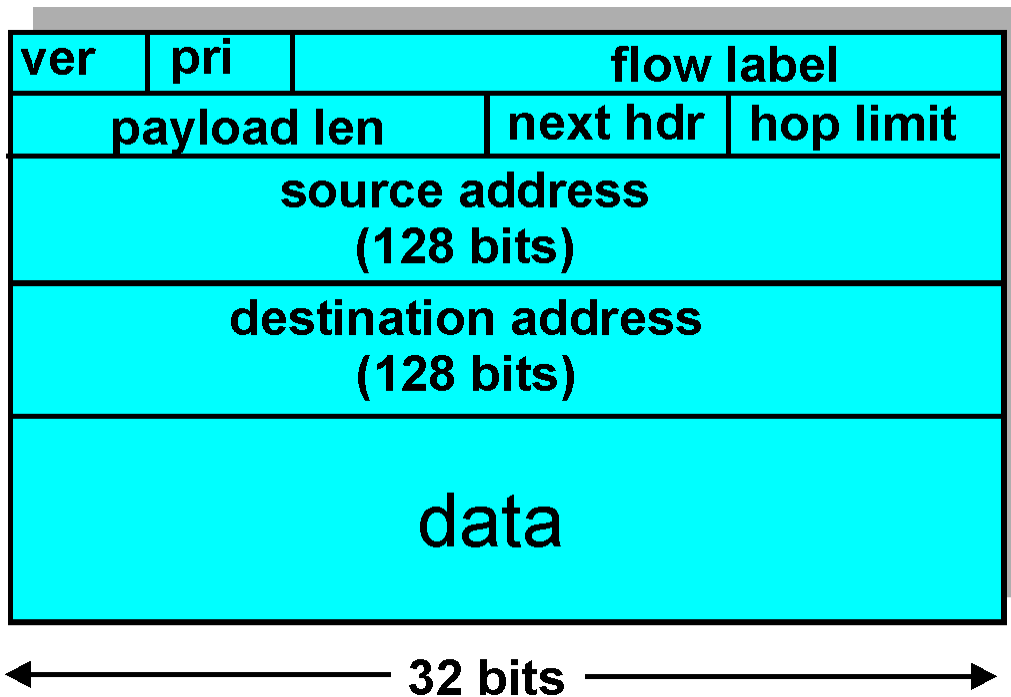

Other Changes from IPv4

- ❑ *Checksum*: removed entirely to reduce processing time at each hop
- ❑ *Options*: allowed, but outside of header, indicated by Next Header field
- ❑ *ICMPv6*: new version of ICMP
 - additional message types, e.g. "Packet Too Big"
 - multicast group management functions

Transition From IPv4 To IPv6

- ❑ Not all routers can be upgraded simultaneously
 - no flag days
 - How will the network operate with mixed IPv4 and IPv6 routers?
- ❑ Two proposed approaches:
 - *Dual Stack*: some routers with dual stack (v6, v4) can translate between formats
 - *Tunneling*: IPv6 carried as payload in IPv4 datagram among IPv4 routers

Dual Stack Approach

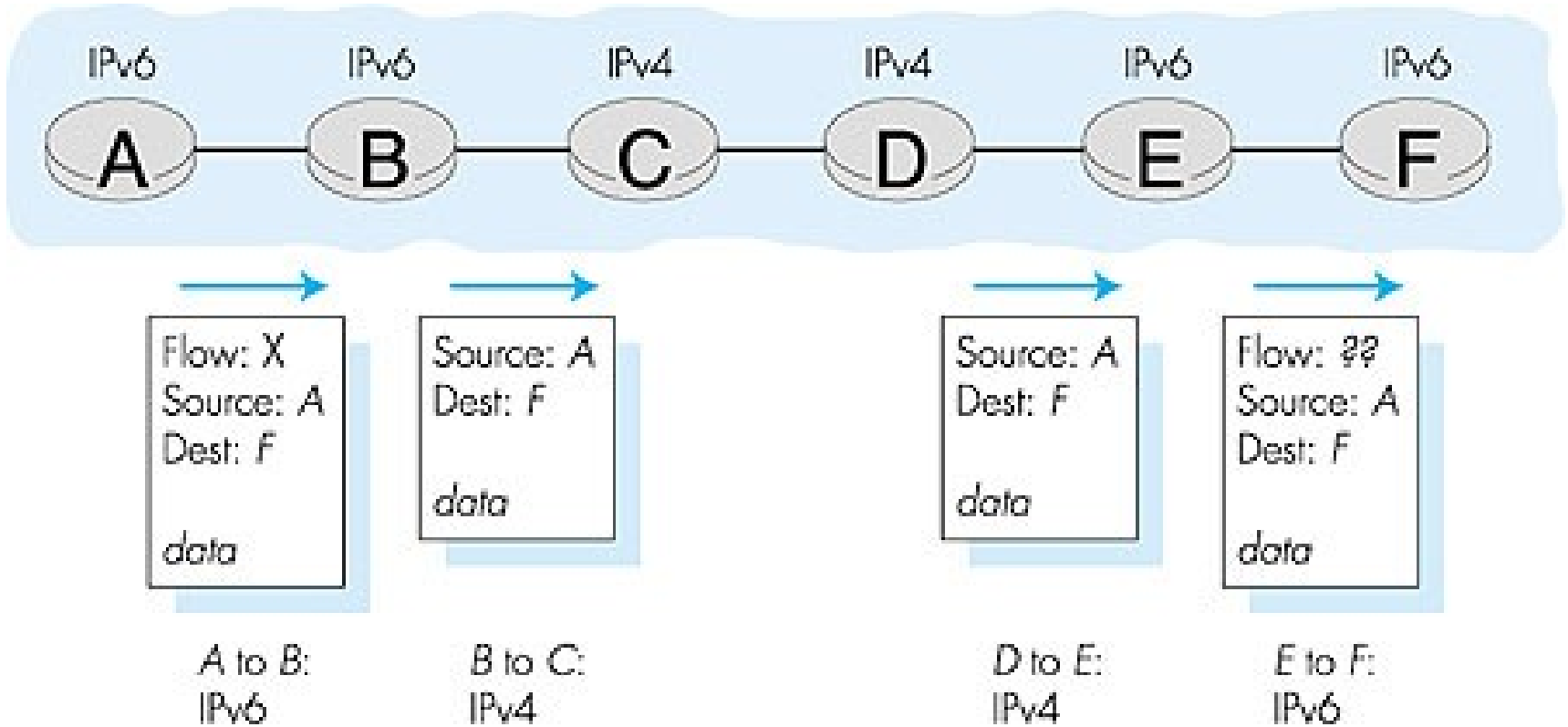

Tunneling

Logical view



Physical view

