

Shear stress tolerance and biochemical characterization of *Phaeodactylum tricornutum* in quasi steady-state continuous culture in outdoor photobioreactors

Asterio Sánchez Mirón^a, M. Carmen Cerón García^a, Antonio Contreras Gómez^a,
Francisco García Camacho^a, Emilio Molina Grima^a, Yusuf Chisti^{b,*}

^a Department of Chemical Engineering, University of Almería, E-04071 Almería, Spain

^b Institute of Technology and Engineering, Massey University, Private Bag 11 222, Palmerston North, New Zealand

Received 9 October 2002; accepted after revision 20 February 2003

Abstract

A bubble column and two airlift photobioreactors (a draft-tube sparged vessel and a split-cylinder device) of the same general design (0.19 m column diameter, 2 m tall, 0.06 m³ working volume) were evaluated for outdoor continuous culture of the microalga *Phaeodactylum tricornutum* at a dilution rate of 0.03 h⁻¹. At a daily averaged irradiance (photosynthetically active) value of 900 μE m⁻² s⁻¹, all bioreactors attained a quasi steady-state biomass concentration of ~1 kg m⁻³ and a biomass productivity of ~0.3 kg m⁻³ per day when the aeration velocity was 0.01 m s⁻¹. The microalgal cells were susceptible to aeration-associated hydrodynamic stress if the superficial aeration velocity exceeded 0.01 m s⁻¹. Supplementing the culture medium with 0.02% or more carboxymethyl cellulose (CMC), allowed stable culture under conditions that had previously damaged the cells.

The average elemental composition of the biomass was: 49.2% C, 6.3% H, 0.8% N, and 1.3% S. The chlorophylls, carotenoids, and pigments content of the biomass changed with irradiance within a given day. Low irradiance favored accumulation of the light capture pigments. Increasing daily irradiance led to accumulation of carbohydrates. Some of the carbohydrate accumulated during the day was consumed at night and partly converted to proteins. Eicosapentaenoic acid (EPA, 20:5n3) constituted between 27 and 30% of the total fatty acids present, or 2.6–3.1% of the dry biomass. The other main fatty acids present were palmitic acid (16:0), palmoleic acid (16:1n7), and myristic acid (14:0). On average, these three fatty acids constituted 16.9% (16:0), 14.0% (16:1n7) and 9.4% (14:0) of the total fatty acids present.

© 2003 Elsevier Science B.V. All rights reserved.

Keywords: *Phaeodactylum tricornutum*; Microalgal culture; Photobioreactors; Airlift reactors

1. Introduction

Photosynthetic microorganisms such as microalgae can provide numerous high-value products [1]. Potential commercial products of microalgal culture include polyunsaturated fatty acids [2], natural colorants [1,3], biopolymers, and therapeutics [1,4]. The microalgae *Phaeodactylum tricornutum* and *Monodus subterraneus*, for example, are particularly good sources of eicosapentaenoic acid, a polyunsaturated fatty acid with important emerging therapeutic applications [5–10].

Of the various possible culture methods [1,11,12], continuous outdoor culture using sunlight appears to be the only viable option for many microalgae. Culture in fully con-

tained (monoseptic) photobioreactors becomes necessary especially if the desired product is to be used in pharmaceutical applications and the producer alga requires a culture environment that is not highly selective only for the alga of interest. Most studies of contained algal culture have used narrow-bore (typically, a diameter less than 0.08 m) continuous run tubes or tubes arranged as parallel rungs with feed and harvest headers, to produce the biomass. These horizontal tubular bioreactors occupy large land areas and are expensive to build and operate [13,14].

This work details the continuous monoseptic outdoor culture of the alga *P. tricornutum* for eicosapentaenoic acid production and characterizes the biochemical composition of the biomass produced in bubble column and airlift [15] photobioreactors. Production performance of three vertical reactors (a bubble column, a split-cylinder airlift device, and a draft-tube airlift bioreactor) of the same overall configura-

* Corresponding author. Tel.: +64-6-350-5934; fax: +64-6-350-5604.
E-mail address: y.chisti@massey.ac.nz (Y. Chisti).

tion, is compared. These relatively large-diameter (diameter >0.1 m) vertical column reactors are compact, low-cost, and easy to operate monoseptically. In addition, vertical column reactors are a realistic option for producing large quantities of microalgal biomass. Little information exists on characterization of microalgal culture in large outdoor bubble columns and airlift vessels. The biochemical composition of the biomass produced is discussed, as being important for determining the suitability of the biomass as a source of chemicals.

2. Materials and methods

2.1. The microalga

Phaeodactylum tricornutum UTEX 640 was the microalga used. The culture was obtained from the collection of the University of Texas, Austin, USA. The inoculum for the photobioreactors was grown indoors under artificial

light ($230 \mu\text{E m}^{-2} \text{s}^{-1}$ light flux at the vessel's surface) in a 201 bubble column (0.15 m diameter) aerated at 1 vvm. The preculture medium was identical to that used in the final reactor cultivation (see later).

2.2. The photobioreactors and culture medium

Three kinds of photobioreactors were used: a bubble column, a split-cylinder airlift device and a concentric draft-tube airlift vessel sparged in the draft-tube (Fig. 1). All vessels were made of 3.3 mm thick, transparent poly(methyl methacrylate), except for the lower 0.25 m sections that were made of stainless steel (Fig. 1). The vessels were 0.193 m in internal diameter. The riser-to-downcomer cross-sectional area ratio was unity for the split-cylinder and 1.24 for the draft-tube airlift vessel. The internal diameter of the draft-tube was 0.144 m. The draft-tube and the baffle were located 0.091 and 0.096 m from the bottoms of the reactors, respectively. The gas-free liquid height was about 2 m in all cases, to provide a working volume of 0.06 m^3 . The

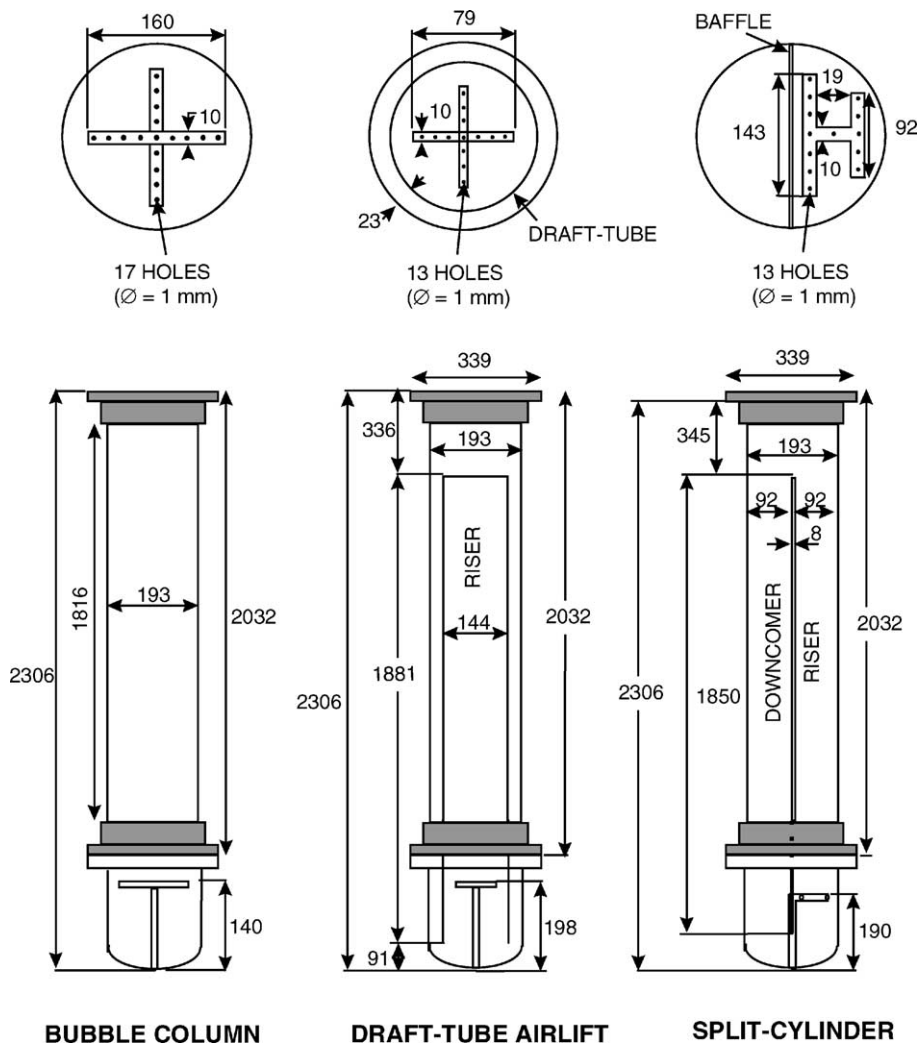

Fig. 1. The configurations of photobioreactors and air spargers. All dimensions in mm.

fluid was mixed by sparging with air through perforated pipe spargers (13–17 holes of 1 mm diameter) (Fig. 1). The superficial aeration velocity varied between 5×10^{-4} and $4 \times 10^{-2} \text{ m s}^{-1}$, based on the total cross-section of the reactors. The complete geometric details of the culture vessels appear in Fig. 1 [16].

The reactors were located outdoors in Almería ($36^{\circ}50'N$, $2^{\circ}27'W$), Spain. The photosynthetically active irradiance on a horizontal plane at the location of the reactors was measured using a 2π irradiance sensor (LI-190SA, Li-cor Inc., Lincoln, NE, USA). The dissolved oxygen concentration was monitored continuously during the 80 day run, as an indicator of the photosynthetic activity. The monitoring electrodes were calibrated before the run. The culture temperature was controlled at $22 \pm 1^{\circ}\text{C}$ by circulating thermostated water through a jacket (not shown in Fig. 1) that surrounded the lower steel portion of the reactors. The pH was controlled at pH 7.7 by automatically injecting carbon dioxide, as needed. The microporous sparger used for injecting carbon dioxide was different than the main gas sparger. This prevented mixing of CO_2 with the main air supply and enhanced the mass transfer of CO_2 . The cultures were carried out during April and May, when the daily averaged irradiance (photosynthetically active) was $900 \mu\text{E m}^{-2} \text{ s}^{-1}$ on a horizontal surface located in the vicinity of the reactors.

Prior to the 80 day continuous run, the reactors were cleaned of salt deposits. Thus, the reactor was filled with tap water, concentrated hydrochloric acid (40 ml, 35% (w/w) HCl) was added, and the water was aerated for at least 2 h. The reactor was then emptied and rinsed with tap water. For sterilization, the reactors and associated pipework were filled with filtered seawater (0.06 m^3), 30 ml of sodium hypochlorite (10% solution) was added, and the fluid was allowed to circulate for 2 h. The reactors were then rinsed with filter sterilized seawater until the pH of the rinse became pH 7.6. The reactors were now filled with the medium.

The culture medium was a modified Ukeles [17] medium [18] made in filter sterilized Mediterranean sea water at twice the components concentrations noted in Table 1. The medium was supplemented with sodium nitrate at a concentration of 1 kg m^{-3} . The composition of seawater has been published [14]. The medium (0.05 m^3) was inoculated using 0.01 m^3 of inoculum in the late exponential growth phase.

Table 1
Composition of the medium

Component	Concentration (kg m^{-3})
$\text{NaH}_2\text{PO}_4 \cdot 2\text{H}_2\text{O}$	0.016
Na_2EDTA	0.01
Fe(III) citrate	4.9×10^{-3}
$\text{MnCl}_2 \cdot 4\text{H}_2\text{O}$	9.9×10^{-4}
ZnCl_2	1.36×10^{-4}
$\text{CoCl}_2 \cdot 6\text{H}_2\text{O}$	2.4×10^{-5}
$\text{CuSO}_4 \cdot 5\text{H}_2\text{O}$	2.5×10^{-5}
$\text{Na}_2\text{MoO}_4 \cdot 2\text{H}_2\text{O}$	2.42×10^{-4}

The biomass concentration in the freshly inoculated reactors was about 0.07 kg m^{-3} . The culture began in the batch mode and the flow of sterile medium (i.e. continuous culture) commenced when the biomass concentration had exceeded 1.5 g l^{-1} . The medium was fed at a constant metered rate to provide the desired dilution rate. The continuous culture setup is shown in Fig. 2.

In a few cases, the aeration rate was increased to $>0.01 \text{ m s}^{-1}$ and the cultures were allowed to reestablish a new steady-state. Cultures aerated at $>0.01 \text{ m s}^{-1}$ gas velocity were generally supplemented with 0.02–0.04% carboxymethyl cellulose (CMC) in the medium, to help protect the cells against shear-induced damage.

2.3. Biomass recovery

The broth harvested from continuous cultures was stored in tanks (0.13 m^3). The biomass was recovered by processing the broth through a continuous centrifuge (Westfalia LG205-1, Germany) running at $6300 \times g$. The recovered biomass paste (approximately 80% water content) was washed with saline (NaCl, 9% (w/w)). The washed paste was freeze dried (Edwards freeze drier, model-4K).

2.4. Analytical methods

2.4.1. Cell viability

Cell viability was determined by the Trypan blue dye exclusion method. Thus, 0.2 ml of microalgal suspension was diluted with 0.3 ml of sterile saline (NaCl, 9% (w/w)) and mixed with 0.5 ml of Trypan blue solution (0.4% (w/v)). The mixture was held for 5–15 min. Nonviable cells took up the blue dye. The live and dead cells were counted in a Neubauer chamber under an optical microscope, to calculate the percentage of the viable cells.

2.4.2. Cellular fluorescence

The photosynthetic state of the culture was monitored by measuring the fluorescence [19] in a fluorimeter (9917 Sensorial Pea, Hansatech Instruments Ltd., UK). For the measurement, a 2 ml sample taken from the bioreactor was immediately placed in a vial (PEA capped vial, 980234) and held in the dark for 5 min. After this period, the fluorimeter illuminated the sample with a saturating red light flash of 0.3 s duration, to provide the following values: F_0 , the minimum value of fluorescence attributed to chlorophyll a [20]; F_m , the maximum fluorescence value reached [21]; F_v , the variable fluorescence value ($F_v = F_m - F_0$); and the ratio F_v/F_m .

2.4.3. Biomass concentration

The biomass concentration was determined spectrophotometrically by reading the culture absorbance at a wavelength of 625 nm. A calibration curve related the optical density and the dry biomass concentration.

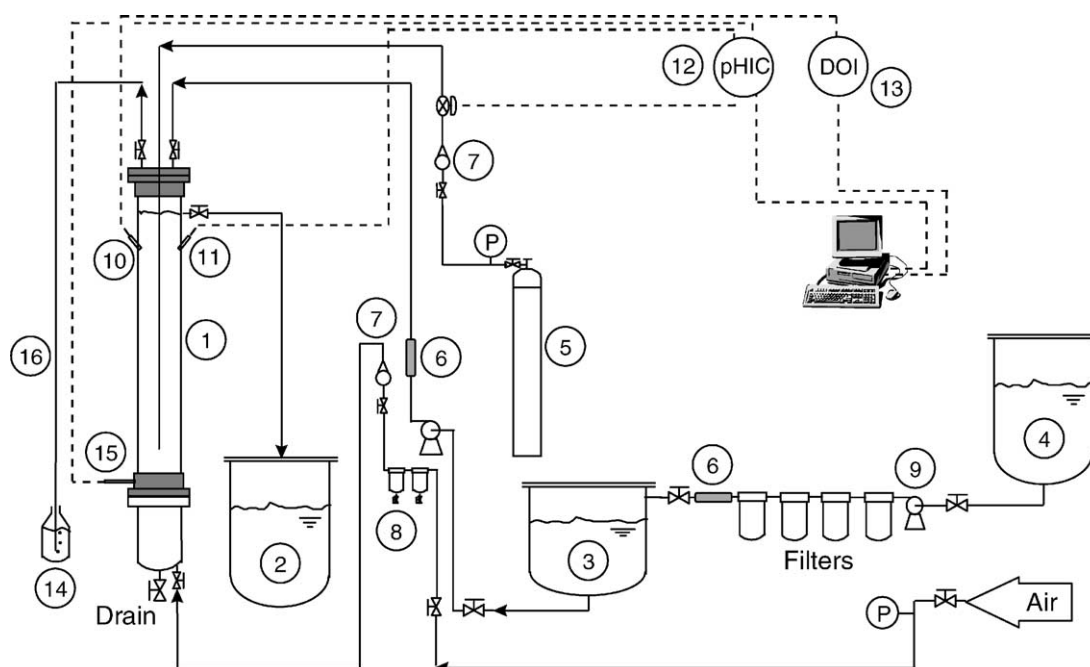

Fig. 2. Continuous culture setup: (1) bioreactor; (2) harvest tank; (3) medium tank; (4) seawater reservoir; (5) carbon dioxide cylinder; (6) UV lamp; (7) flow meter; (8) air filters; (9) pump; (10) dissolved oxygen electrode; (11) pH electrode; (12) pH indicator and controller; (13) dissolved oxygen indicator; (14) sodium hypochlorite solution; (15) temperature probe; (16) exhaust gases.

2.4.4. Total carbohydrates

The anthrone-sulfuric acid method suitably adapted for microalgal biomass [22] was used. Thus, 8 ml of perchloric acid (20% (w/w)) was added to algal biomass (100 mg) in a round-bottomed flask (100 ml). The mixture was ultrasonicated for 10 min and left to hydrolyze for 12 h. The mixture was filtered and diluted to 250 ml using distilled water. Freshly prepared anthrone reagent (5 ml) was added to 1 ml of the filtrate. The resulting mixture was raised to 100 °C over a period of 12 min. A green color developed because of the formation of a glucose-anthrone complex. The mixture was cooled (ice bath) and the optical density was read at a wavelength of 630 nm against a blank of the anthrone reagent (5 ml) mixed with distilled water (1 ml). The anthrone reagent had been prepared by dissolving anthrone (10 mg) in 100 ml of sulfuric acid (72% (w/w)). A calibration curve was prepared for each experiment, using D + glucose dissolved in distilled water.

2.4.5. Fatty acids

The fatty acids were determined as methyl esters. The esters were prepared using the direct transesterification method of Lepage and Roy [23], as modified by Rodriguez-Ruiz et al. [24]. Thus, 1 ml of a freshly prepared methylation mixture (20:1 (v/v) methanol-acetyl chloride) was added to dry biomass (10 mg) in a test tube. The mixture was ultrasonicated for 15 min and hexane (0.5 ml) was added. The mixture was heated (104 °C heater block) for 10 min. The mixture was cooled to room temperature and 1 ml of distilled water was added. The hexane phase was used in subsequent analy-

ses. For the fatty acid quantification, 5 µl of a nonadecanoic acid solution (C19:0) was added as an internal standard, to the biomass before methylation of esters. The nonadecanoic acid solution had been prepared by dissolving pure acid (25 mg, Sigma catalog number N5252) in toluene (1 ml).

The methyl esters were detected and quantified by gas chromatography (Hewlett-Packard model 5890 Series II gas chromatograph; Hewlett Packard Company, Avondale, PA) on OmegawaxTM (Supelco, Bellefonte, PA, USA) column (30 m length, 0.25 mm internal diameter, 0.2 mm thickness of the stationary phase). The column temperature program was as follows: 185 °C for 10 min; 4.2 °C min⁻¹ rise until 240 °C, and 240 °C for 3 min. The carrier gas (nitrogen) flow rate was 1.1 ml min⁻¹. The injector and detector were held at 240 and 260 °C, respectively. The sample volume was 5 µl.

The specific fatty ester peaks were identified by comparing with the elution pattern of a standard mixture of n-3 polyunsaturated fatty acids (Matreya, Pleasant Gap, PA; catalog number 1177). For quantification of the fatty esters, the nonadecanoic ester (19:0) internal pattern was used. Each sample contained 0.125 mg of 19:0. Because a flame-ionization detector has the same sensitivity for all fatty esters, the correction factors for the various esters and the internal standard were the same. The amount of any fatty acid *i* in the biomass (mg fatty acid per g biomass), could be calculated with the following equation:

$$\text{fatty acid } i (\text{mg g}^{-1}) = 0.125 \frac{F_i A_i}{F_S A_{Sm}} \quad (1)$$

where 0.125 mg is the amount of internal standard added to the sample, F_i is the response factor for the fatty acid i , A_i is the area of the peak for the fatty ester i , F_S is the response factor for the standard, A_S is the area of the peak for the internal standard, and m is the amount of biomass (mg). For the detector used, F_i and F_S are unity.

2.4.6. Elemental composition

The elemental composition (C, H, N, S) of the culture supernatant and the biomass was determined using an elemental analyzer (LECO CHNS-932 with oxygen furnace VTF900). The sample size was 2 mg for lyophilized biomass and 5 ml for culture supernatant. The samples were completely oxidized over a catalyst (Cu–CuO) at 1050 °C and the resulting oxidation gases were analyzed by infrared detectors selective for water, CO₂ and SO₂. The oxidation products of nitrogen were determined by a thermal conductivity detector. The equipment provided values for C, N, S and H of the dry biomass. For the culture supernatant samples, only the N content were relevant because dissolved carbon dioxide contributed to the carbon present and the hydrogen content were mostly water.

2.4.7. Total protein

The total protein (%) in the biomass samples was calculated as 6.25 times the total percent nitrogen in the sample. The latter had been determined by elemental analysis. This procedure was equivalent to the determination of protein by the Kjeldhal method, as demonstrated by Reboloso Fuentes et al. [25] for the microalgal biomass of interest in the present study.

2.4.8. Chlorophylls

The spectrophotometric method of Hansmann [26] was used for estimating the chlorophylls contents in the cells. A culture volume corresponding to 5 mg dry biomass was centrifuged (800 × g, 2 min) to recover the cells. The biomass was resuspended in acetone–water mixture (8 ml, 90% (v/v) acetone) to extract the pigments. A mark on the glass tube indicated the exact volume of the slurry. The tube was shaken vigorously, ultrasonicated for 10 min, and allowed to stand in the dark at 4 °C for 48 h. Further processing occurred at room temperature. Acetone was added to compensate for any evaporation and the sample was centrifuged (800 × g, 5 min). The supernatant was recovered and its optical density was read at 665, 645 and 630 nm wavelengths in a spectrophotometer. The following equations [26] were used to calculate the concentrations of chlorophylls:

$$Ch_a = 11.6OD_{665} - 1.31OD_{645} - 0.14OD_{630} \quad (2)$$

$$Ch_b = 20.7OD_{645} - 4.34OD_{665} - 4.42OD_{630} \quad (3)$$

$$Ch_c = 55.0OD_{630} - 4.64OD_{665} - 16.3OD_{645} \quad (4)$$

where Ch_a , Ch_b and Ch_c are the concentrations (mg l⁻¹) of chlorophyll a, b and c, respectively, and OD is the optical density measured at the specified wavelength. The optical

density measurements were made in cuvettes of 1 cm light path. If the absorbance value exceeded 0.8 units, the sample was diluted with the solvent (acetone–water) to bring the measurement within range.

2.4.9. Carotenoids

Carotenoids were determined by a suitably modified procedure of Whyte [27]. Thus, the culture volume equivalent to 5 mg dry biomass was immediately treated with aqueous potassium hydroxide (1 ml, 60% (w/w) KOH) to hydrolyze the lipids. The mixture was subjected to ultrasound for 10 min, homogenized, warmed to 40 °C for 40 min, and left on a shaker in the dark for 24 h at 4 °C. The carotenoids were extracted using 1 ml portions of ethyl ether until the organic extract was clear. The solvent in the combined extract was evaporated with nitrogen and 5 ml of acetone was added. The optical density of the resulting solution was read at 444 nm wavelength in a spectrophotometer. The total carotenoids were calculated as follows:

$$C_t = 4.32OD_{444} - 0.0439 \quad (5)$$

where C_t is the carotenoids content in mg l⁻¹.

3. Results and discussion

3.1. Biomass yield, productivity and shear stress

At 0.03 h⁻¹, the selected dilution rate of continuous culture was nearly half of the maximum specific growth rate attained within the illuminated period of a given day in batch culture [16,28]. The culture was fed continuously as a chemostat only during the daylight hours (10 h daily). Feeding ceased during the night. The volumetric biomass productivity was calculated by multiplying the dilution rate by the average biomass concentration in the broth collected during the 10 h workday. The reactors operated at a quasi steady-state. The steady-state biomass concentration attained was ~1 kg m⁻³ at an aeration velocity of 0.01 m s⁻¹. The volumetric productivity of the biomass was 0.34 kg m⁻³ per day in the split-cylinder bioreactor operated at a superficial aeration velocity of 0.01 m s⁻¹. At this aeration velocity, the cell viability was close to 100%.

For the same alga cultured in a 0.03 m diameter horizontal tubular photobioreactor, a maximum biomass productivity value of 2.76 kg m⁻³ per day was attained at a dilution rate of 0.04 h⁻¹ [29]. Although, the volumetric productivity of the narrow-bore horizontal tubular reactor was ~9-fold more than the productivity observed in the vertical column reactors, the latter had an areal productivity that was ~4 times that of the horizontal tubular device.

At relatively high values of aeration rates (superficial aeration velocity U_G based on the total cross-section of the column, of ≥0.015 m s⁻¹), in the CMC-supplemented medium, the stable biomass concentrations attained in the bubble column were significantly greater than the corresponding

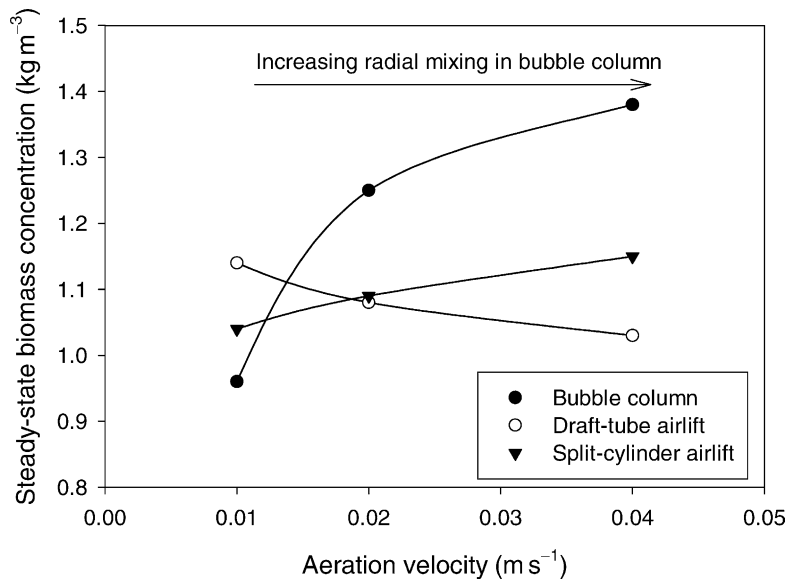

Fig. 3. Steady-state biomass concentrations attained in the various reactors at different values of aeration velocities.

concentrations in the two airlift vessels (Fig. 3). The increasing productivity of the bubble column with increasing aeration rate (Fig. 3) was attributed to improved radial mixing, which caused frequent movement of cells from the darker core of the reactor to the better illuminated periphery. Reducing the length of exposure to a continuous dark period is known to enhance the photosynthetic efficiency of algal cells and, consequently, the biomass productivity [30–32]. Increasing aeration rate in the airlift vessels had barely any effect on radial mixing because the radial movement of fluid was restricted by the splitting baffle and the draft-tube.

The cultures did not experience photoinhibition, as confirmed by an average value (12 measurements total, made on four different days) and standard deviation of the F_v/F_m ratio of 0.567 ± 0.046 . The F_v/F_m ratio was measured at 13:00 h local time when the irradiance was maximum on the reactors' surface. A maximum F_v/F_m ratio of 0.6 has been reported for low-intensity indoor illumination ($150 \mu\text{E s}^{-1} \text{m}^{-2}$) of algae such as *Dunaliella* and suggests a healthy culture that is not photoinhibited [33]. Under relatively high irradiance, a F_v/F_m ratio of >0.55 is taken to indicate an absence of photoinhibition [33] and photodamage.

The effects of aeration-induced hydrodynamic stress on the biomass concentration are shown in Fig. 4 for the bubble column. Initially, in region (a) of Fig. 4, the culture was at a superficial gas velocity of 0.01 m s^{-1} (specific power input of 98 W m^{-3}) and at a stable steady-state biomass concentration of approximately 1 kg m^{-3} . At the instance of the arrow A (Fig. 4), the aeration rate was raised to 0.02 m s^{-1} (specific power input of 196 W m^{-3}). The biomass concentration began to decline as the cells lysed. The concentration declined to less than 0.04 kg m^{-3} . No steady-state was attained and if the aeration rate had been maintained at 0.02 m s^{-1} , the culture would have washed out. At the instance of the

arrow B (Fig. 4), the aeration rate was reduced to the original value of 0.01 m s^{-1} and gradually the cell concentration rose to eventually attain a concentration of $\sim 1 \text{ kg m}^{-3}$, the steady-state value before the instance A when the aeration rate was first raised. Clearly, an aeration rate of greater than about 0.01 m s^{-1} was damaging to the cells.

At the instance of the arrow C, the aeration rate was raised from 0.010 to 0.015 m s^{-1} (specific power input of 147 W m^{-3}). The cell concentration declined to an eventual steady-state value of $\sim 0.7 \text{ kg m}^{-3}$. At the arrow D, the aeration rate was raised to a damaging value of 0.02 m s^{-1}

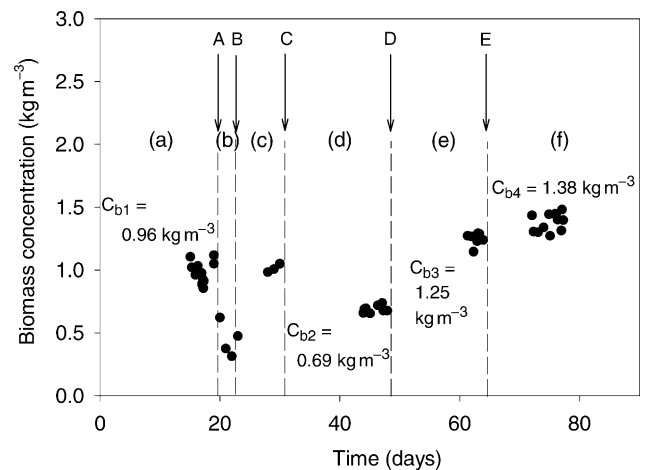

Fig. 4. Biomass concentration in bubble column versus time in continuous culture. C_{b1-4} are the steady-state biomass concentrations attained. No steady-state occurred in region (b). The aeration rate (U_G , m s^{-1}) values for various periods were: (a) 0.01; (b) 0.02; (c) 0.01; (d) 0.015; and (e) 0.04. The culture was supplemented with carboxymethyl cellulose (CMC) in regions (e) and (f) only, at CMC concentrations of 0.02 and 0.04%, respectively.

but the continuous culture medium was supplemented with 0.02% carboxymethyl cellulose, a known shear-protectant [34–36] that is not metabolized by *P. tricornutum*. This time the steady-state biomass concentration stabilized at 1.25 kg m^{-3} , a value greater than the stable concentration attained at the lowest aeration rate tested. The ability to attain a high stable biomass concentration under conditions that had previously damaged the cells severely, demonstrated a clear shear-protective effect of CMC on algal cells.

At the instance of the arrow E, the aeration rate was raised further to 0.04 m s^{-1} (specific power input of 392 W m^{-3}) and simultaneously the concentration of CMC was increased to 0.04%. No cell damage was observed and a high steady-state biomass concentration was attained. These experiments provide a clear demonstration of the cell protective effect of CMC and the damaging effects of aeration on algal cells. Supplementation of the culture medium with CMC increased the average bubble size. Bursting of large bubbles at the surface of culture is known to release less energy and cause less damage than the bursting of small bubbles [34,35]. This was the primary mechanism of the protective effect of CMC. Presence of CMC also dampened turbulence at the scale of the terminal eddies; however, even in the absence of CMC and at the lowest aeration rate the dimensions of the terminal eddies were significantly greater than the cell diameter [36]. The results in the airlift reactors were quite similar to those shown in Fig. 4.

3.2. Composition of the biomass

The biochemical composition of the microalgal biomass can be beneficially manipulated by controlling the culture environment. The biochemical composition is affected mainly by temperature, pH, the irradiance history, and the nitrogen content of the medium. Data on biomass composition of *P. tricornutum* cultured under indoor constant illumination have been reported [37,38], but large-scale indoor culture (artificial illumination) is prohibitively expensive and therefore impractical. The biomass composition data from outdoor cultures have generally come from horizontal tubular reactors [39–41] and not from vertical columns.

In quasi steady-state outdoor continuous culture, the cells necessarily experience a continuous change in irradiance and this affects the composition of the biomass. Also, the type of photobioreactor used for cultivation can significantly influence the biomass composition. The configuration of the photobioreactor determines whether there is an excessive accumulation of the photosynthetically generated oxygen in the culture, the occurrence of photoinhibition and photooxidation, the light-dark cycling frequency, and the irradiance history of the biomass. All data reported in this section pertain to bioreactor operation at 0.01 m s^{-1} aeration rate when the hydrodynamic stress was not a significant limiting factor and the medium did not contain any shear-protective additives (the presence of CMC as a shear-protectant in the cul-

ture medium had no effect on the biochemical composition of the cells).

3.2.1. Pigments

Natural colorants and pigments are important products of some microalgal culture processes [3,42]. Accumulation of the pigments in the biomass is an indicator of the physiological state of the culture [43], particularly of the extent of photolimitation of the cells. Photolimited cultures generally contain an elevated concentration of photocapture pigments because of the need to harvest the limited amount of light available. Also, the extent of pigmentation of the biomass influences the depth to which light penetrates in the broth; hence, the irradiance profile in a bioreactor is a function of the pigment content.

Fig. 5 shows the variation in pigment content of the biomass with time of day during quasi steady-state culture at a constant biomass concentration ($\sim 1 \text{ kg m}^{-3}$) in the three photobioreactors ($U_G = 0.01 \text{ m s}^{-1}$). The variation of pigment content with time is quite similar in the three bioreactors, suggesting generally similar irradiance profiles in all vessels. Pigments concentration in the cells responds quite rapidly to changes in irradiance, or time of day, as shown in Fig. 5. As expected, the pigment content declines as irradiance increases from early morning (10:00 h) to about 13:00 h. At midday, $\sim 14:30$ h local time, there is an increase in pigments contents because in bubble column and airlift bioreactors the irradiance is relatively low when the Sun is directly overhead (i.e. at midday) [14]. Towards 17:00 h, the pigments contents decrease again (Fig. 5) as the irradiance increases. With the approach of night (beyond 17:00 h in Fig. 5), the irradiance declines and the pigment content in the cells rise rapidly.

3.2.2. Chlorophylls

At a fixed irradiance in batch culture, an increasing cell population causes a decline in irradiance in bioreactors and the cells respond by increasing their chlorophyll and carotenoids contents [28,44]. A similar effect was observed in continuous culture where the biomass concentration was constant but because of outdoor placement of reactors, the irradiance varies with the time of day. A general decline in the chlorophylls and carotenoids content in the biomass with increasing irradiance occurred, as shown in Fig. 6 for the three bioreactors. However, the carotenoids were much less sensitive to irradiance than were the chlorophylls.

The average chlorophyll content of the biomass produced in the three bioreactors in this work was 1.37%, or almost 1.5-fold greater than the chlorophyll contents in biomass generated in a horizontal-tube bioreactor of 0.06 m tube diameter [45]. The horizontal-tube reactor was operated at a dilution rate of 0.0252 h^{-1} (quasi steady-state operation) and at the same time of the year as our reactors. This suggests that the narrow-bore horizontal tube experienced greater averaged irradiance values than in our reactors, even though the biomass concentration in the horizontal tubular device was

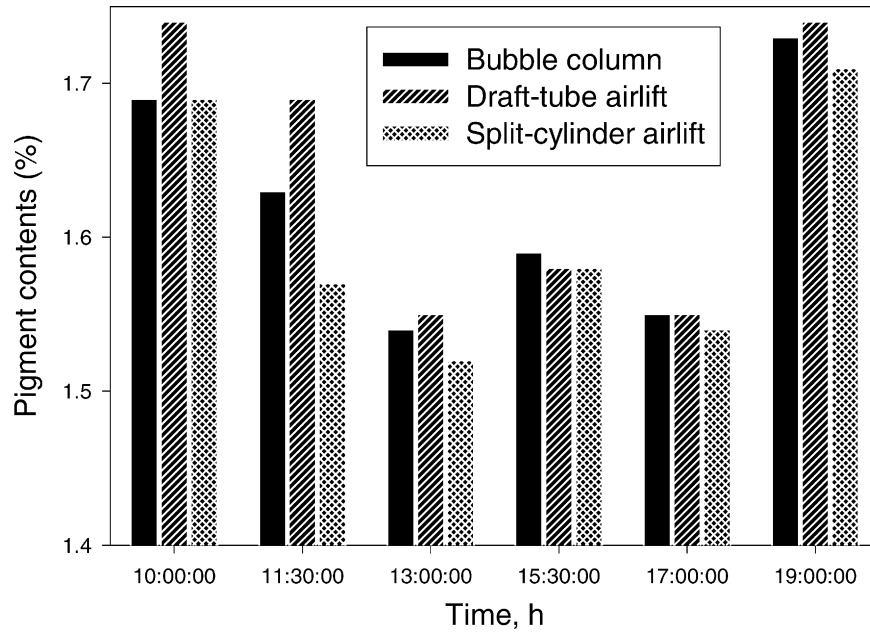

Fig. 5. Pigment contents of biomass versus time within one daylight period in quasi steady-state culture in the three bioreactors ($U_G = 0.01 \text{ m s}^{-1}$).

approximately 6 kg m^{-3} compared to our 1 kg m^{-3} (nearly 100% viable). Measurements confirm that at any daylight hour, the irradiance inside a horizontally oriented tube of a given diameter is always greater than in the same tube mounted with the long axis vertical [46].

Photoinhibition, a situation in which an increase in irradiance produces a decrease in the rate of photosynthesis, can cause an increase in cellular chlorophyll content. (Photoinhibition inactivates chlorophyll and more of it must be syn-

thesized.) Measurements of cellular fluorescence confirmed that the cells were not photoinhibited and the changes in pigments contents in our reactors were exclusively due to changes in irradiance.

3.2.3. Carotenoids

As shown in Fig. 6, the carotenoids content of the biomass declined only slightly as the irradiance increased. Although a photoprotective effect has been ascribed to carotenoids in

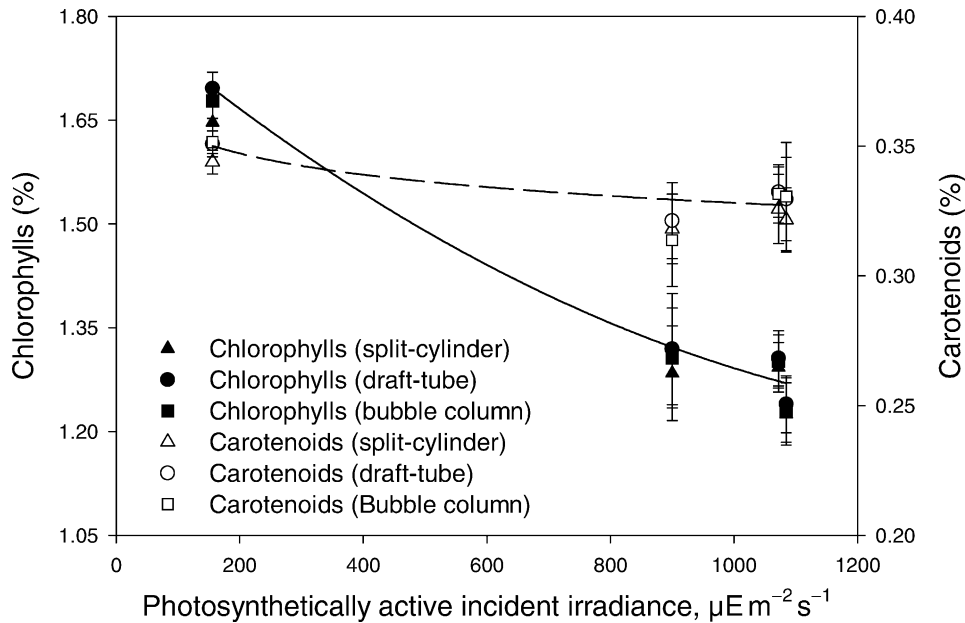

Fig. 6. Chlorophylls and carotenoids contents of biomass as a function of the photosynthetically active incident irradiance on a horizontal surface in the vicinity of the three vertical bioreactors ($U_G = 0.01 \text{ m s}^{-1}$).

the past, a decline in carotenoids with increasing irradiance suggests that up to an irradiance level of $\sim 1100 \mu\text{E s}^{-1} \text{m}^{-2}$, the cells did not initiate a carotenoids-mediated photoprotective response. This further supports that the cultures never experienced irradiance intense enough to cause photoinhibition. It is possible that if the cells were faced with photoinhibition and photooxidation, they would have responded by accumulating carotenoids.

3.2.4. Fatty acids

Lipids are important storage products of *P. tricornutum*. Some of the fatty acids produced by the alga are potentially significant high-value therapeutics and nutraceuticals. In continuous culture, the dilution rate (i.e. the specific growth rate) has a major influence on the lipid contents of the biomass. Dilution rate determines the mean residence time of the cells in the reactor and, therefore, the average age of the cells. At high dilution rates, the rapidly growing young cells contain less storage lipids and more proteins than cells cultured at lower dilution rates [37,47].

In the present work, the dilution rate was held constant at 0.03h^{-1} and only the incident irradiance varied with the daily cycle. The proportion of the various fatty acids in the biomass was barely affected by the time of day and, therefore, by incident irradiance. The total fatty acid contents of the biomass were constant at between 8.4 and 10.0% in the three reactors at all steady-states.

Based on the fatty acid profile by gas chromatography of the *P. tricornutum* lipids, the alga contained more than 20 fatty acids. Of these, four were present at more than 8% of the total fatty acid contents. Eicosapentaenoic acid (EPA, 20:5n3) constituted between 27 and 30% of the total fatty acids, or 2.6–3.1% of the dry biomass. The other main fatty acids present were palmitic acid (16:0), palmoleic acid (16:1n7), and myristic acid (14:0). On average, these three fatty acids constituted 16.9% (16:0), 14.0% (16:1n7) and

9.4% (14:0) of the total fatty acids present. All minor fatty acids represented approximately 30% of the total fatty acids.

The average productivity of EPA in the three bioreactors was $8.6 \times 10^{-3} \text{kg m}^{-3}$ per day. Because EPA productivity is directly dependent on the biomass concentration in the culture broth, bioreactors that can support high biomass concentrations (e.g. small diameter tubes) can achieve productivities that are several fold greater than attained in this work. EPA productivity of $48 \times 10^{-3} \text{kg m}^{-3}$ per day, or more, can be attained in *P. tricornutum* cultures. The EPA contents of the biomass in the vertical reactors were similar to the values obtained in a horizontal tubular reactor of 0.06 m tube diameter [39]. However, the areal productivity of EPA was seven-fold greater in the vertical reactors than in the horizontal tubular device.

3.2.5. Proteins and carbohydrates

The protein and carbohydrate contents of the biomass were similar for material harvested from the three bioreactors (Fig. 7). The biomass contained an average of $\sim 50\%$ protein by weight. This value was comparable to 57% protein contents reported for *Spirulina* [48]. Other work reported 30–70% protein in *P. tricornutum* biomass [49]. The average carbohydrate contents of the biomass was $\sim 9.5\%$ in the present work but this can be as high as $\sim 28\%$ when *P. tricornutum* is cultured under continuous light (no dark periods) of a non-photoinhibiting intensity [37].

Protein contents tend to be low in older cells than in the rapidly growing younger cells, as explained in Section 3.2.4. At the relatively low dilution rate used (i.e. a low specific growth rate), the protein contents were significantly less than the 70% reported by Chrismadha and Borowitzka [49]. The protein and carbohydrate contents of the biomass varied with time of day, as shown in Fig. 7 for the daylight hours. Because of photosynthesis, carbohydrates accumulated in the cells through the day and the protein content decreased

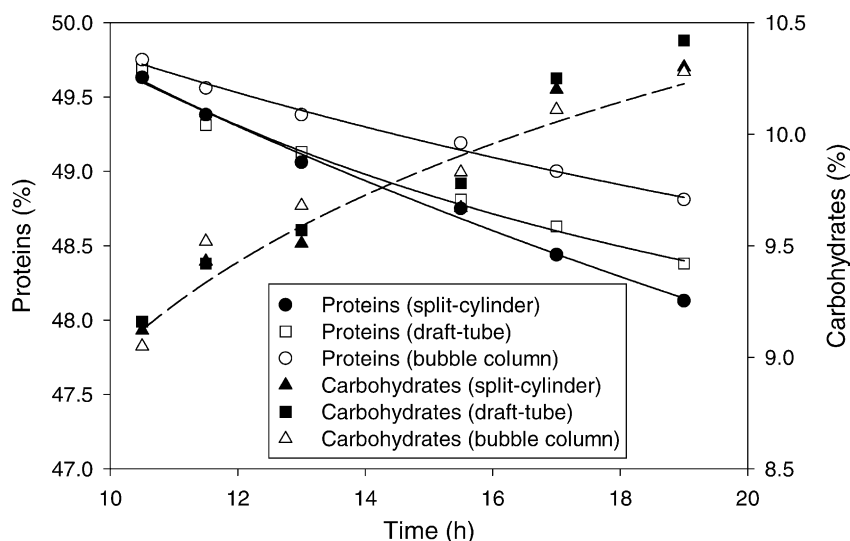

Fig. 7. Proportion of proteins and carbohydrates in algal biomass for various times of day in the three bioreactors ($U_G = 0.01 \text{m s}^{-1}$).

proportionately. At night, a significant proportion of the accumulated carbohydrates was consumed to support cellular metabolism. During the night, the proportion of proteins in the cells increased partly because of synthesis of new protein and partly because some of the storage components (mainly carbohydrates) were consumed. A high irradiance in narrow diameter tubes generally favors a biomass with a lower proportion of proteins than does the relatively low irradiance environment of the vertical reactors used in this study.

3.2.6. Elemental composition

The quasi steady-state grown biomass contained on average 49.2% C, 6.3% H, 0.8% N and 1.3% S. The carbon was contained mainly in carbohydrates and lipids. All the carbon was derived by photosynthetic fixation of the carbon dioxide supplied to the culture. The rate of carbon fixation was 2.5 mg C per liter per h. The nitrogen and sulfur were mainly associated with proteins. Based on the nitrogen content of the cells and the amount of nitrogen supplied, the culture medium always had a substantial excess of nitrogen. This was confirmed by elemental analysis of the cell-free broth which had 0.1% residual nitrogen.

4. Concluding remarks

Long-term quasi steady-state outdoor continuous culture of *P. tricornutum* could be carried out successfully in large-diameter (diameter >0.15 m) vertical column photobioreactors. The main conclusions of the study are the followings:

1. The vertical orientation of relatively large-diameter column bioreactors permits microalgal culture that does not experience photoinhibition even when the culture is relatively dilute ($\sim 1 \text{ kg m}^{-3}$ biomass concentration) and the incident irradiance is sufficiently intense to cause photoinhibition in narrow-bore horizontal tubes.
2. The biomass productivity based on the land area occupied, of vertical column bioreactors greatly exceeds the areal productivity of conventional horizontal tube reactors even though the narrow-bore horizontal tubes can attain higher volumetric productivities than the vertical reactors.
3. In bubble columns and airlift reactors of 2 m static fluid height, a superficial aeration velocity of $\geq 0.01 \text{ m s}^{-1}$ can damage *P. tricornutum* cells, but the damage can be prevented by supplementing the culture with $\geq 0.02\%$ carboxymethyl cellulose.
4. In continuous outdoor culture of a constant biomass concentration, the pigments, chlorophylls and carotenoids content of the biomass increase with declining irradiance.
5. The carbohydrate contents of the biomass increase during the day but up to 20% of the carbohydrate accumulated during the day is consumed at night.
6. At a constant specific growth rate, the proportion of proteins in the biomass declines with increasing irradiance.
7. At the dilution rate used (0.03 h^{-1}), the total fatty acids contents of the cell were virtually independent of irradiance. The fatty acids constituted between 8 and 10% of the algal cell mass.
8. The main fatty acid of interest, eicosapentaenoic acid (EPA), constituted between 27 and 30% of the total fatty acids present, or 2.6–3.1% of the dry biomass.

In view of the above, the biochemical characteristics of the biomass in quasi steady-state outdoor culture vary throughout the day because of changes in irradiance. The biochemical composition also varies during the night because of continuous preferential consumption of the energy reserve compounds.

Acknowledgements

This research was supported by the Comision Interministerial de Ciencia y Tecnología (CICYT) (BIO98-0522), Spain, and the European Union (Project BRPR CT97-0537).

References

- [1] O. Pulz, K. Scheibenbogen, W. Gross, Biotechnology with cyanobacteria and microalgae, in: H.-J. Rehm, G. Reed (Eds.), Biotechnology, vol. 10, VCH, Weinheim, 2001, pp. 105–136.
- [2] E.H. Belarbi, E. Molina, Y. Chisti, A process for high yield and scaleable recovery of high purity eicosapentaenoic acid esters from microalgae and fish oil, *Enzyme Microb. Technol.* 26 (2000) 516–529.
- [3] R.T. Lorenz, G.R. Cysewski, Commercial potential for *Haematococcus* microalgae as a natural source of astaxanthin, *Trends Biotechnol.* 18 (2000) 160–167.
- [4] M.A. Borowitzka, Pharmaceuticals and agrochemicals from microalgae, in: Z. Cohen (Ed.), Chemicals from Microalgae, Taylor & Francis, London, 1999, pp. 313–352.
- [5] M.L. Burr, A.M. Fehily, J.F. Gilbert, S. Rogers, R.M. Holliday, P.M. Sweetnam, P.C. Elwood, N.M. Deadman, Effects of changes in fat, fish, and fibre intakes on death and myocardial reinfarction: diet and reinfarction trial (DART), *Lancet* 2 (1989) 757–761.
- [6] M. de Lorgeril, S. Renaud, N. Mamelle, P. Salen, J.L. Martin, I. Monjaud, J. Guidollet, P. Touboul, J. Delaye, Mediterranean alpha-linolenic acid-rich diet in secondary prevention of coronary heart disease, *Lancet* 343 (1994) 1454–1459.
- [7] J.H. Christensen, P. Gustenhoff, E. Korup, J. Aaroe, E. Toft, J. Moller, K. Rasmussen, J. Dyerberg, E.B. Schmidt, Effect of fish oil on heart rate variability in survivors of myocardial infarction: a double blind randomised controlled trial, *Br. Med. J.* 312 (1996) 677–678.
- [8] M. Peet, J. Brind, C.N. Ramchand, S. Shah, G.K. Vankar, Two double-blind placebo-controlled pilot studies of eicosapentaenoic acid in the treatment of schizophrenia, *Schizophr. Res.* 49 (2001) 243–251.
- [9] D.F. Horrobin, M. Peet, A dose-ranging study of ethyl-eicosapentaenoate in treatment-unresponsive depression, *Biol. Psychiatr.* 49 (2001) 37S.
- [10] D.F. Horrobin, C.N. Bennett, M. Peet, Correlation between clinical improvement and red cell fatty acid changes when treating schizophrenia with eicosapentaenoic acid, *Schizophr. Res.* 49 (2001) 232.

- [11] O. Pulz, Photobioreactors: production systems for phototrophic microorganisms, *Appl. Microbiol. Biotechnol.* 57 (2001) 287–293.
- [12] Y. Chisti, M. Moo-Young, Bioreactors, in: R.A. Meyers (Ed.), *Encyclopedia of Physical Science and Technology*, vol. 2, Academic Press, San Diego, 2002, pp. 247–271.
- [13] E. Molina Grima, F.G. Ación Fernández, F. García Camacho, Y. Chisti, Photobioreactors: light regime, mass transfer, and scale up, *J. Biotechnol.* 70 (1999) 231–247.
- [14] A. Sánchez Mirón, A.C. Gómez, F.G. Camacho, E.M. Grima, Y. Chisti, Comparative evaluation of compact photobioreactors for large-scale monoculture of microalgae, *J. Biotechnol.* 70 (1999) 249–270.
- [15] Y. Chisti, *Airlift Bioreactors*, Elsevier, New York, 1989, p. 355.
- [16] A. Sánchez Mirón, F. García Camacho, A. Contreras Gómez, E. Molina Grima, Y. Chisti, Bubble column and airlift photobioreactors for algal culture, *AIChE J.* 46 (2000) 1872–1887.
- [17] R. Ukeles, The effect of temperature on the growth and survival of several marine algae species, *Biol. Bull.* 120 (1961) 255–264.
- [18] J.L. García Sánchez, Estudio multifactorial de nutrientes para el crecimiento de la microalga marina *Isochrysis galbana*. Evaluación en un fotobiorreactor tubular externo, Ph.D. Thesis, University of Almería, Spain, 1994.
- [19] C.S. Ting, T.G. Owens, The effects of excess irradiance on photosynthesis in the marine diatom *Phaeodactylum tricoratum*, *Plant Physiol.* 106 (1994) 599–605.
- [20] G.H. Krause, E. Weis, Chlorophyll fluorescence and photosynthesis: the basics, *Annu. Rev. Plant Physiol. Plant Mol. Biol.* 42 (1991) 313–349.
- [21] O. Van Kooten, J.F.H. Snel, The use of chlorophyll fluorescence nomenclature in plant stress physiology, *Photosynth. Res.* 25 (1993) 147–1150.
- [22] D.R. Osborne, *Análisis de Nutrientes de los Alimentos*, Acribia, Zaragoza, 1985, pp. 136–153.
- [23] C. Lepage, C. Roy, Improved recovery of fatty acids through direct transesterification without prior extraction or purification, *J. Lipid Res.* 25 (1984) 1391–1396.
- [24] J. Rodríguez-Ruiz, E.-H. Belarbi, J.L. García Sánchez, D. López Alonso, Rapid simultaneous lipid extraction and transesterification for fatty acid analyses, *Biotechnol. Tech.* 12 (1998) 689–691.
- [25] M.M. Rebollos Fuentes, A. Navarro Pérez, J.J. Ramos Miras, J.L. Guil Guerrero, Biomass nutrients profiles of the microalga *Phaeodactylum tricoratum*, *J. Food Biochem.* 25 (2001) 57–76.
- [26] E. Hansmann, Pigment analysis, in: J.R. Stein (Ed.), *Handbook of Phycological Methods, Culture Methods and Growth Measurements*, Cambridge University Press, London, 1973, pp. 359–368.
- [27] J.C. Whyte, Biochemical composition and energy content of six species of phytoplankton used in mariculture of bivalves, *Aquaculture* 60 (1987) 231–241.
- [28] A. Sánchez Mirón, M.-C. Cerón García, F. García Camacho, E. Molina Grima, Y. Chisti, Growth and biochemical characterization of microalgal biomass produced in bubble column and airlift photobioreactors: studies in fed-batch culture, *Enzyme Microb. Technol.* 31 (2002) 1015–1023.
- [29] E. Molina Grima, J.M. Fernández Sevilla, J.A. Sánchez Pérez, F. García Camacho, A study on simultaneous photolimitation and photoinhibition in dense microalgal cultures tanking into account incident and averaged irradiances, *J. Biotechnol.* 45 (1996) 59–69.
- [30] E. Molina Grima, F.G. Ación Fernández, F. García Camacho, F. Camacho Rubio, Y. Chisti, Scale-up of tubular photobioreactors, *J. Appl. Phycol.* 12 (2000) 355–368.
- [31] E. Molina Grima, J. Fernández, F.G. Ación, Y. Chisti, Tubular photobioreactor design for algal cultures, *J. Biotechnol.* 92 (2001) 113–131.
- [32] M. Janssen, P. Slenders, J. Tramper, L.R. Mur, R.H. Wijffels, Photosynthetic efficiency of *Dunaliella tertiolecta* under short light/dark cycles, *Enzyme Microb. Technol.* 29 (2001) 298–305.
- [33] E.S. Jin, J.E.W. Polle, A. Melis, Involvement of zeaxanthin and of the Cbr protein in the repair of photosystem II from photoinhibition in the green alga *Dunaliella salina*, *Biochem. Biophys. Acta Bioenerg.* 1506 (2001) 244–259.
- [34] Y. Chisti, Shear sensitivity, in: M.C. Flickinger, S.W. Drew (Eds.), *Encyclopedia of Bioprocess Technology: Fermentation, Biocatalysis, and Bioseparation*, vol. 5, Wiley, New York, 1999, pp. 2379–2406.
- [35] Y. Chisti, Animal-cell damage in sparged bioreactors, *Trends Biotechnol.* 18 (2000) 420–432.
- [36] F. García Camacho, E. Molina Grima, A. Sánchez Mirón, V. González Pascual, Y. Chisti, Carboxymethyl cellulose protects algal cells against hydrodynamic stress, *Enzyme Microb. Technol.* 29 (2001) 602–610.
- [37] Q. Kaixian, M.A. Borowitzka, Light and nitrogen deficiency effects on the growth and composition of *Phaeodactylum tricoratum*, *Appl. Biochem. Biotechnol.* 38 (1992) 93–103.
- [38] E. Molina Grima, J.A. Sánchez Pérez, F. García Camacho, J.M. Fernández Sevilla, F.G. Ación Fernández, J. Urda Cardona, Biomass and eicosapentaenoic acid productivities from an outdoor batch culture of *Phaeodactylum tricoratum* UTEX 640 in an air-lift photobioreactor, *Appl. Microbiol. Biotechnol.* 42 (1994) 658–663.
- [39] E. Molina Grima, J.A. Sánchez Pérez, F. García Camacho, J.M. Fernández Sevilla, F.G. Ación Fernández, J. Urda Cardona, Outdoor chemostat culture of *Phaeodactylum tricoratum* UTEX 640 in a tubular photobioreactor for the production of eicosapentaenoic acid, *Biotechnol. Appl. Biochem.* 20 (1994) 279–290.
- [40] E. Molina Grima, J.A. Sánchez Pérez, F. García Camacho, J.M. Fernández Sevilla, F.G. Ación Fernández, J. Urda Cardona, Biomass and EPA productivities from an outdoor batch of *Phaeodactylum tricoratum* UTEX 640 in an airlift tubular photobioreactor, *Appl. Microbiol. Biotechnol.* 24 (1995) 658–663.
- [41] F.G. Ación Fernández, F. García Camacho, J.A. Sánchez Pérez, J.M. Fernández Sevilla, E. Molina Grima, Modeling of biomass productivity in tubular photobioreactors for microalgal cultures: effects of dilution rate, tube diameter and solar irradiance, *Biotechnol. Bioeng.* 58 (1998) 605–616.
- [42] K.E. Apt, P.W. Behrens, Commercial development in microalgal biotechnology, *J. Phycol.* 35 (1999) 215–226.
- [43] V. Veloso, A. Reis, L. Gouveia, H.L. Fernandes, J.A. Empis, J.M. Novais, Lipid production in *Phaeodactylum tricoratum*, *Bioresour. Technol.* 38 (1991) 115–119.
- [44] M.W. Fawley, Effects of light intensity and temperature interactions on growth characteristics of *Phaeodactylum tricoratum* (Bacillariophyceae), *J. Phycol.* 20 (1984) 67–72.
- [45] F.G. Ación Fernández, Operaciones en continuo de fotobiorreactores tubulares externos con la microalga *Phaeodactylum tricoratum*, Ph.D. Thesis, University of Almería, Spain, 1996.
- [46] F. García Camacho, A. Contreras Gómez, F.G. Ación Fernández, J.M. Fernández Sevilla, E. Molina Grima, Use of concentric-tube airlift photobioreactors for microalgal outdoor mass cultures, *Enzyme Microb. Technol.* 24 (1999) 164–172.
- [47] A. Reis, L. Gouveia, V. Veloso, H.L. Fernandes, J.A. Empis, J.M. Novais, Eicosapentaenoic acid-rich biomass production by the microalga *Phaeodactylum tricoratum* in a continuous-flow reactor, *Bioresour. Technol.* 55 (1996) 83–88.
- [48] G. Torzillo, A. Sacchi, R. Materassi, Temperature as an important factor affecting productivity and night biomass loss in *Spirulina platensis* grown outdoors in tubular photobioreactors, *Bioresour. Technol.* 38 (1991) 95–100.
- [49] T. Chrismadha, M.A. Borowitzka, Effect of cell density and irradiance on growth, proximate composition and eicosapentaenoic acid production by *Phaeodactylum tricoratum* grown in a tubular photobioreactor, *J. Appl. Phycol.* 6 (1994) 67–74.