



Julius Robert Mayer



James Prescott Joule



Hermann Helmholtz



James Clerk Maxwell



Rudolf Clausius



Ludwig Boltzmann



Max Planck

Thermodynamics

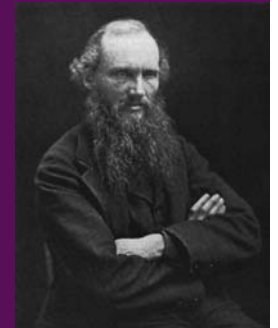

Lord William Thomson Kelvin

Dr Matthias Lein (lecture notes by: Prof. Peter Schwerdtfeger)

*New Zealand Institute for Advanced Study
Centre of Theoretical Chemistry and Physics
Building 44 (Oteha Rohe)*

<http://ctcp.massey.ac.nz/>

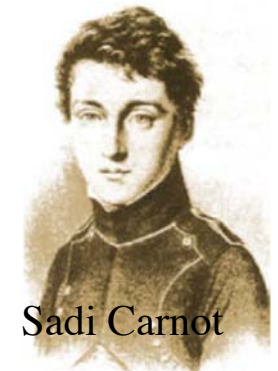

Sadi Carnot

Textbooks: Halliday/Resnick/Walker, *Fundamental of Physics*, 6th ed., Wiley (2003).
Serway/Jewett, *Physics for Scientist & Engineers*, Thomson (2004).

27/07/08

Temperature, Heat and the First Law of Thermodynamics

■ What is Thermodynamics?

- **Thermodynamics** (from the Greek θερμη, **therme**, meaning *heat* and δυναμις, **dynamis**, meaning *power*) is a branch of physics that studies the effects of changes in **temperature** T , **pressure** P , and **volume** V on physical systems (gases, liquids and solids). It is the study of **thermal energy** which uses the temperature T as its basic concept.
- **Classical Thermodynamics** is a **macroscopic theory** describing properties of systems which contain a large number of atoms or molecules (of the order of Avogadro's number, $N_A = 6.023 \times 10^{23} \text{ mol}^{-1}$). It usually does not consider an atomic interpretation (quantum theory).
- **Macroscopic** properties are connected to **microscopic** properties. Microscopic properties are described by **quantum theory**. They enter thermodynamics in a statistical way, they are used in **statistical thermodynamics**.

■ What is Thermodynamics?

- The foundation of classical thermodynamics is built on four **postulates** (the four laws of thermodynamics).
- Thermodynamics can be used in a wide variety of **applications** in science and engineering, such as chemical reactions, phase transitions, transport phenomena, engines, and in astronomy describing stars and black holes. The results of thermodynamics are essential for other fields of physics and for chemistry, chemical engineering, aerospace engineering, mechanical engineering, cell biology, chemical and biological evolution, biomedical engineering, and materials science.

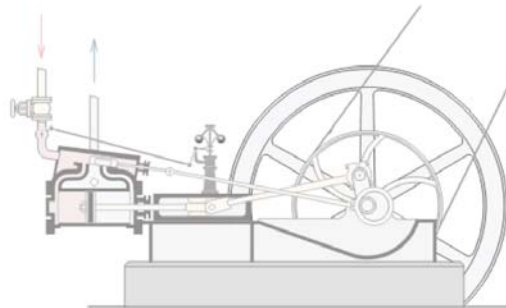
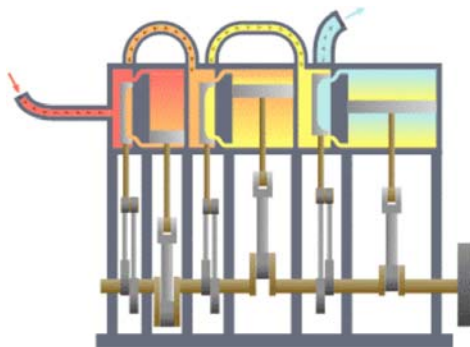

Is it difficult to understand Thermodynamics?

Thermodynamics is a funny subject. The first time you go through it, you don't understand it at all. The second time you go through it, you think you understand it, except for one or two small points. The third time you go through it, you know you don't understand it, but by that time you are so used to it, it doesn't bother you any more.

Arnold Sommerfeld

Every mathematician knows it is impossible to understand an elementary course in thermodynamics.

V.I. Arnold



In this house, we obey the laws of thermodynamics!

Homer Simpson, after Lisa constructs a perpetual motion machine whose energy increases with time, in *The Simpsons*.

It's the Second Law of Thermodynamics: Sooner or later everything turns to shit.

Woody Allen, in *Husbands and Wives* (1992)

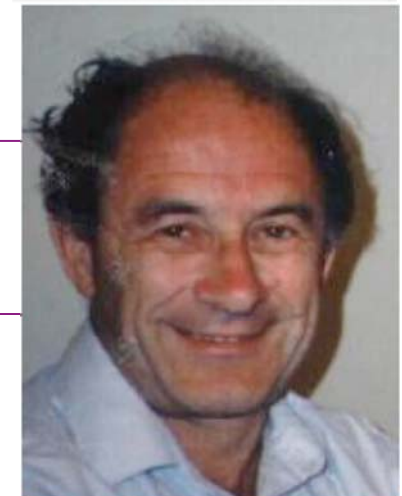



The Laws of Classical Thermodynamics

- *Zeroth Law*: A state function exists, the **temperature** T , which has the same value in all systems which are in thermal equilibrium.
- *First Law*: Law of **conservation of energy**, i.e. in an isolated system the total energy remains constant.
- *Second Law*: Law of **increasing entropy**, e.g. heat always flows from the warmer to the colder system.
- *Third Law*: The **absolute zero temperature**, $T = 0$ K (-273.15°C), cannot be reached in finite steps.



What can thermodynamics do?

Thermodynamics can describe

- *Phase changes* (solid to liquid, liquid to gas, change in the crystal structure)
- *Heat transfer* (cooling systems, thermal conductance, convection, etc.).
- *Thermal expansion* (Solid, liquid or gas).
- *Chemical reactions* (equilibrium constants → chemical thermodynamics)
- *Non-existence of a perpetuum mobile* (perpetual motion machine, machine which constantly does work without consumption of energy)



Temperature and State Functions

- A **state function** is a property of the system which is independent of how the state is reached. Typical state functions are the *temperature* T , the *pressure* P , the *volume* V , the *number of particles* in the system N , etc.
- We associate the concept of temperature with how *hot* or *cold* an object feels. **Temperature** can be thought of as the property that determines whether an object is in thermal equilibrium with other objects. In other words: two objects are in *thermal equilibrium* with each other if they have the same temperature (no heat flow).

The Kelvin Scale

- In physics the **Kelvin scale** is used for measuring the temperature. The **Celsius scale** is obtained by

$$T_C [^{\circ}\text{C}] = T_K [\text{K}] - 273.15 \quad (\text{no degree symbol for K})$$

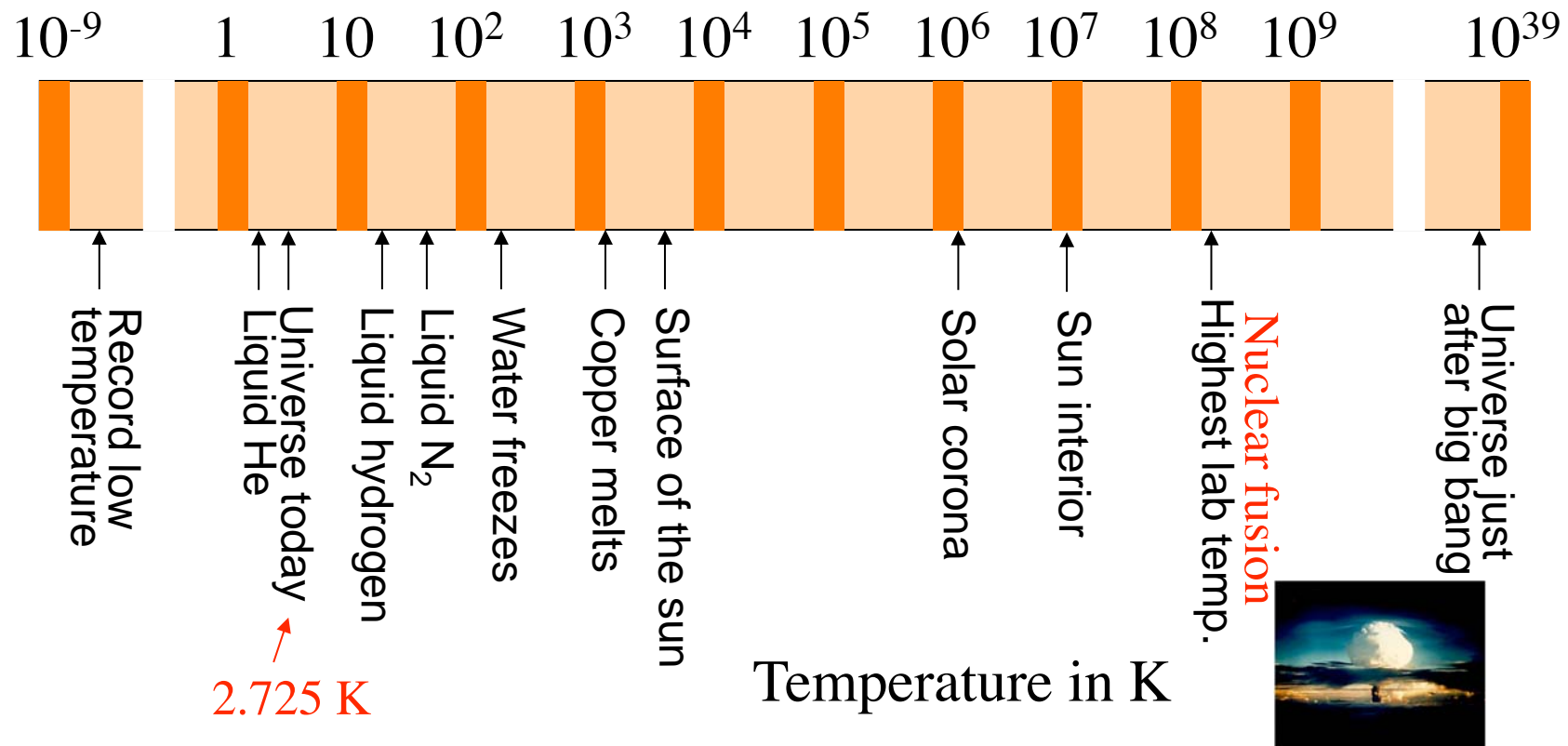



Thermal Equilibrium

- Two objects are in **thermal contact** with each other if energy can be exchanged between them.
 - The exchange we will focus on will be in the form of heat (conduction or convection) or electromagnetic radiation
 - The energy is exchanged due to a temperature difference
- **Thermal equilibrium** is a situation in which two objects would not exchange energy by heat or electromagnetic radiation if they were placed in thermal contact
 - The thermal contact does not have to be a physical contact

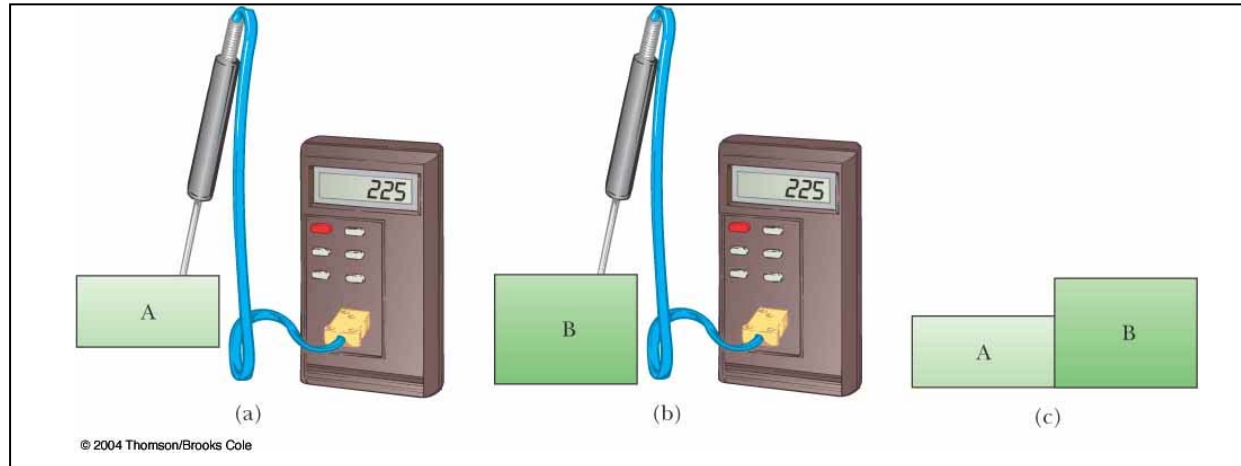

- Object T (thermometer) is placed in contact with A until they achieve thermal equilibrium
 - The reading on T is recorded
- Object T is then placed in contact with object B until they achieve thermal equilibrium
 - The reading on T is recorded again
- If the two readings are the same, A and B are also in thermal equilibrium

Zeroth Law of Thermodynamics

If two bodies A and B are in thermal equilibrium with a third body T, then they are in thermal equilibrium with each other

$$A \overset{\text{TE}}{\rightleftharpoons} T \wedge B \overset{\text{TE}}{\rightleftharpoons} T \Rightarrow A \overset{\text{TE}}{\rightleftharpoons} B$$

Every body has a property called **temperature**. When two bodies are in thermal equilibrium, their temperatures are equal. All properties of each system assume stable values (they do not have to be the same, e.g. the volume can be different for both systems).

- This law establishes the temperature as a valid concept.
- The law was introduced late in the 1930s long after the other three laws were established (therefore zeroth law)



Measuring the Temperature

- A **thermometer** is a device that is used to measure the temperature of a system
- Thermometers are based on the principle that some physical property of a system changes as the system's temperature changes. These properties include:
 - The volume of a liquid
 - The dimensions of a solid
 - The pressure of a gas at a constant volume
 - The volume of a gas at a constant pressure
 - The electric resistance of a conductor
 - The color of an object
- A temperature scale can be established on the basis of any of these physical properties

- A common type of thermometer is a liquid-in-glass thermometer.
- The material in the capillary tube expands as it is heated.
- The liquid is usually mercury or alcohol.
- A thermometer can be calibrated by placing it in contact with some natural systems that remain at constant temperature.
- Common systems involve water:

A mixture of ice and water at atmospheric pressure is called the ice point of water defined as 0°C . A mixture of water and steam in equilibrium is called the steam point of water 100°C . The length of the column between these two points is divided into 100 increments, called degrees.



© 2004 Thomson/Brooks Cole





Problems with liquid-in-glass thermometers:

- An alcohol thermometer and a mercury thermometer may agree only at the calibration points
- The discrepancies between thermometers are especially large when the temperatures being measured are far from the calibration points
 - ➔ Solution: The Constant Volume Gas Thermometer
- The thermometers also have a limited range of values that can be measured
 - Mercury cannot be used below -30°C
 - Alcohol cannot be used above 85°C

Absolute Zero

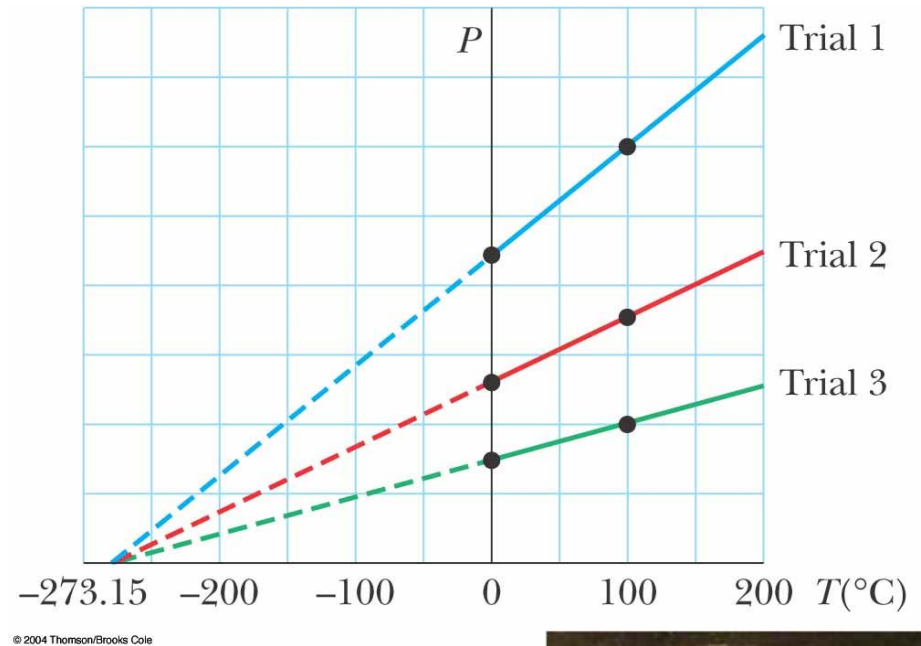
- Gas-thermometer readings are virtually independent of the gas used
- If the lines for various gases are extended, the pressure is always zero when the temperature is -273.15°C
- This temperature is called **absolute zero**
- Absolute zero is used as the basis of the absolute temperature scale
- The size of the degree on the absolute scale is the same as the size of the degree on the Celsius scale,
 $\Delta T_{\text{C}} [^{\circ}\text{C}] = \Delta T [\text{K}]$
- To convert: $T_{\text{C}} [^{\circ}\text{C}] = T [\text{K}] - 273.15$ (named after *Anders Celsius*)



- 
- The absolute temperature scale is now based on two new fixed points:
 - Adopted in 1954 by the International Committee on Weights and Measures
 - One point is absolute zero, the other point is the **triple point** of water (the combination of temperature and pressure where ice, water, and steam can all coexist)
 - The triple point of water occurs at 0.01 °C and 4.58 mm of Hg (611.73 Pa)
 - This temp. is set to be 273.16 K on the absolute temperature scale
 - The units of the absolute scale are **Kelvins** (named after William Thomson Lord Kelvin). **NB: no degree sign for K**
 - According to classical physics, the kinetic energy of the gas molecules would become zero at absolute zero (quantum theory shows that this is not correct)

Thermal Expansion

- **Thermal expansion** is the increase in the size of an object with an increase in its temperature
- Thermal expansion is a consequence of the change in the average separation between the atoms (molecules) in an object
- If the expansion is small relative to the original dimensions of the object, the change in any dimension is, to a good approximation, proportional to the first power of the change in temperature (i.e. linear, first term in a Taylor expansion)
- Assume an object has an initial length L_i . That length increases by ΔL as the temperature changes by ΔT

$$\Delta L = \alpha L_i \Delta T$$

or

$$L_f - L_i = \alpha L_i (T_f - T_i)$$

[m]

[K]

[K⁻¹]

- α is called **coefficient of linear expansion**
(in units of °C⁻¹ or K⁻¹).

- As the washer shown at right is heated, all the dimensions will increase (a and b)
- A cavity in a piece of material expands in the same way as if the cavity were filled with the material
- The expansion is exaggerated in this figure
- Since the linear dimensions change, it follows that the surface area and volume also change with a change in temperature
- Some materials expand along one dimension, but contract along another as the temperature increases

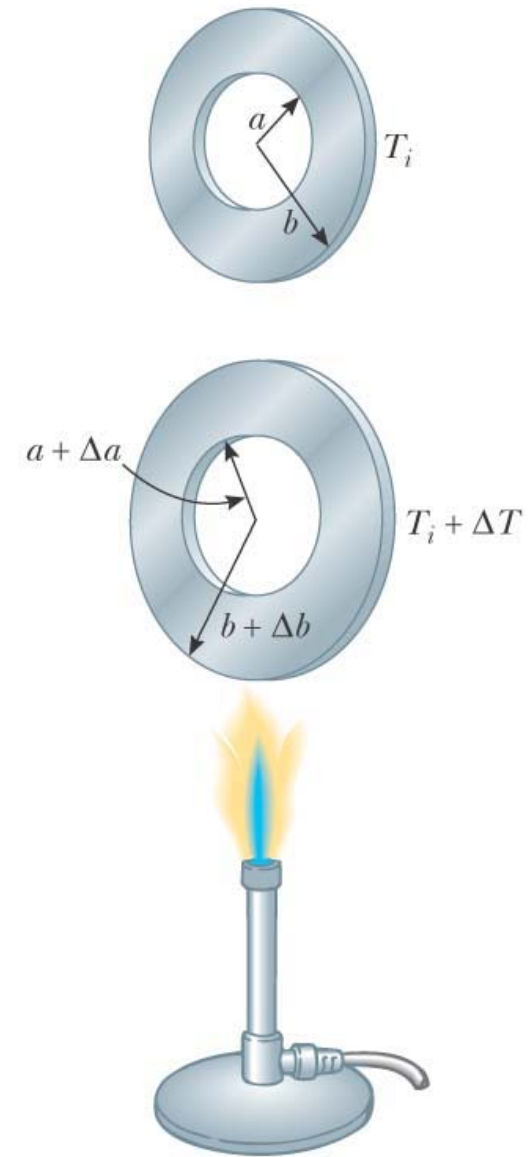

Average Expansion Coefficients for Some Materials Near Room Temperature

Material	Average Linear Expansion Coefficient (α)($^{\circ}\text{C}$) $^{-1}$	Material	Average Volume Expansion Coefficient (β)($^{\circ}\text{C}$) $^{-1}$
Aluminum	24×10^{-6}	Alcohol, ethyl	1.12×10^{-4}
Brass and bronze	19×10^{-6}	Benzene	1.24×10^{-4}
Copper	17×10^{-6}	Acetone	1.5×10^{-4}
Glass (ordinary)	9×10^{-6}	Glycerin	4.85×10^{-4}
Glass (Pyrex)	3.2×10^{-6}	Mercury	1.82×10^{-4}
Lead	29×10^{-6}	Turpentine	9.0×10^{-4}
Steel	11×10^{-6}	Gasoline	9.6×10^{-4}
Invar (Ni-Fe alloy)	0.9×10^{-6}	Air ^a at 0 $^{\circ}\text{C}$	3.67×10^{-3}
Concrete	12×10^{-6}	Helium ^a	3.665×10^{-3}

^a Gases do not have a specific value for the volume expansion coefficient because the amount of expansion depends on the type of process through which the gas is taken. The values given here assume that the gas undergoes an expansion at constant pressure.

1 m of steel expands by
11 μm if T is raised by 1 $^{\circ}\text{C}$

- 
- The change in volume is proportional to the original volume and to the change in temperature

$$\Delta V = \beta V_i \Delta T$$

- β is the coefficient of volume expansion
- For a solid, $\beta \approx 3\alpha$
 - This assumes the material is isotropic, the same in all directions (if not α represents a second-rank tensor, i.e. different values for each dimension in space)

Example: A cube of length L : $V = L^3$

$$\Delta V = \left(\frac{\Delta V}{\Delta L} \right) \Delta L \approx \left(\frac{dV}{dL} \right) \Delta L = (3L^2) \alpha L \Delta T = 3\alpha L^3 \Delta T = \beta V \Delta T$$

➔ $\beta = 3\alpha$

- In many situations, joints are used to allow room for thermal expansion
- The long, vertical joint is filled with a soft material that allows the wall to expand and contract as the temperature of the bricks changes
- Each substance has its own characteristic average coefficient of expansion
- This can be made use of in the device shown, called a bimetallic strip
- It can be used in a thermostat



(a)

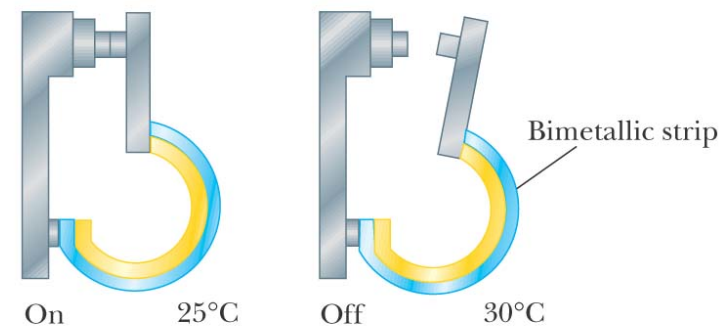

(b)

Other Forces

- Young's Modulus Y
 - Measures the resistance of a solid to a change in its length

$$\left(\frac{F}{A}\right) = Y \left(\frac{\Delta L}{L_0}\right) \quad (\text{Stress}) = (\text{Young's modulus}) (\text{Strain})$$

Y depends on the material (not size/shape).

Units are N/m^2

Combined effect:

$$\left(\frac{\Delta L}{L}\right) = \alpha \Delta T + \frac{1}{Y} \left(\frac{\Delta F}{A}\right)$$

- Shear Modulus G (modulus of rigidity)
 - Measures the resistance to motion of the planes within a solid parallel to each other
- Bulk Modulus B (Compressibility $C=B^{-1}$)
 - Measures the resistance of solids or liquids to changes in their volume

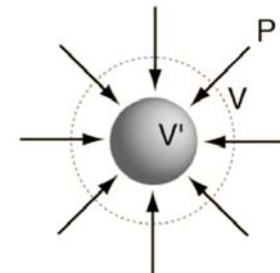
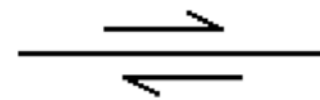
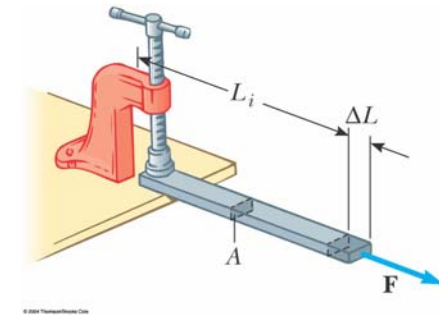

- The *elastic limit* (also called yield strength) is the maximum stress that can be applied to the substance before it becomes permanently deformed
- When the stress exceeds the elastic limit, the substance will be permanently deformed
 - The curve is no longer a straight line, formula breaks down
- With additional stress, the material ultimately breaks

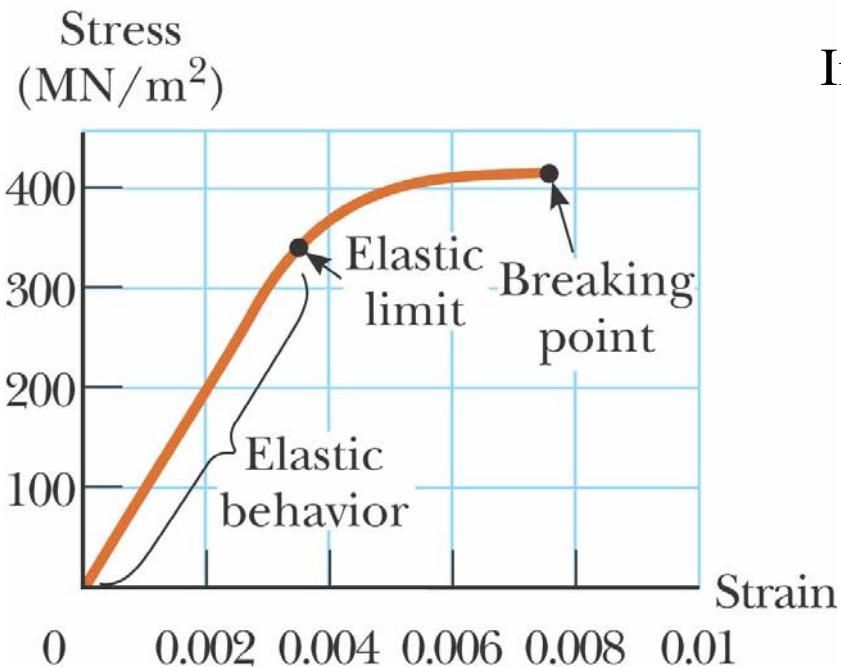

Important in construction engineering!

A relationship between the **coefficient of linear expansion** α (K^{-1}) and the **melting point** T_m ($^{\circ}\text{C}$) of the material:

G. Bonfiglioli, G. Montalenti
Journal of Applied Physics
22, 1089-1090 (1951)

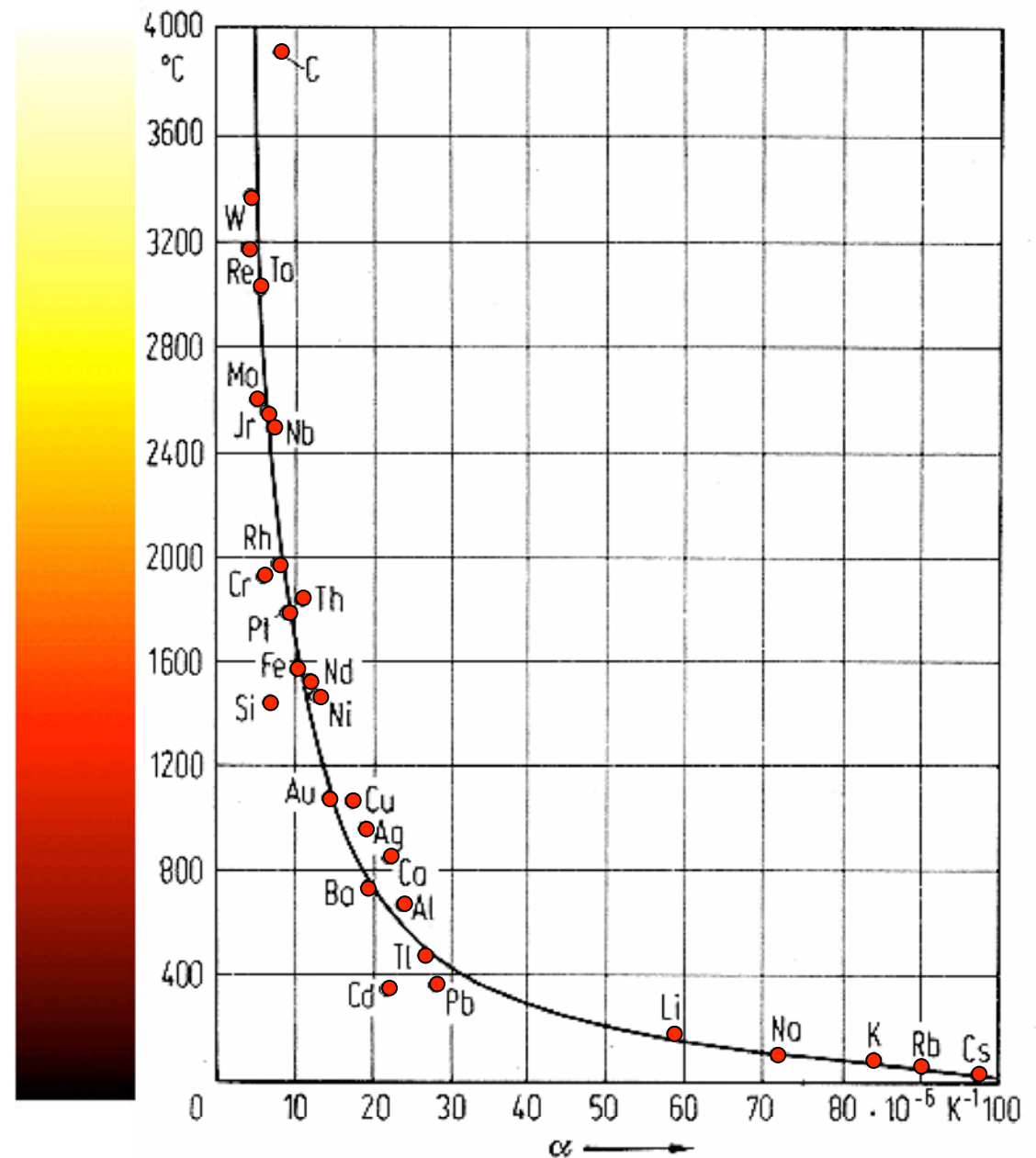

Example: A steel wire stretched between fixed supports

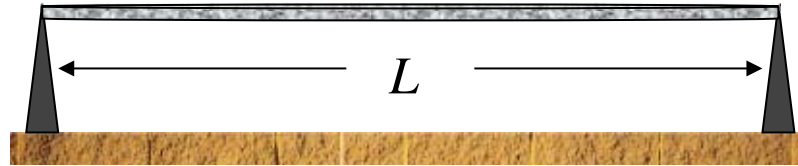

At what temperature T_f does the steel wire go slack ?

What we know: Wire cross section area $A = 1 \text{ mm}^2$ (thin wire)

Tension is 100 N at $T_i = 20^\circ\text{C}$, $Y_{steel} = 200 \text{ GN/m}^2$

$\alpha_{steel} = 11 \times 10^{-6} \text{ K}^{-1}$

Wire goes slack if $\Delta L > 0$ starts, hence we take $\Delta L = 0 \text{ m}$ and $F_{final} = 0 \text{ N}$:

$$\left(\frac{\Delta L}{L}\right) = \alpha \Delta T + \frac{1}{Y} \left(\frac{\Delta F}{A}\right) \Rightarrow \alpha \Delta T + \frac{1}{Y} \left(\frac{\Delta F}{A}\right) = 0$$

Since $\Delta F = F_{final} - F_{initial} = 0 \text{ N} - 100 \text{ N} = -100 \text{ N}$

We get $\Delta T = -\frac{1}{\alpha Y} \left(\frac{\Delta F}{A}\right) = 45 \text{ K} = 45^\circ\text{C} \Rightarrow T_f = T_i + \Delta T = 65^\circ\text{C}$

Current Research in Materials Science: **Colossal Expansion**

■ Most materials contract when they are cooled and get bigger when they are warmed up. But some substances do the opposite by shrinking in certain directions as they are heated and expanding when cooled. Now researchers in the UK have found an inorganic crystalline material composed of silver, cobalt, carbon and nitrogen that expands more than any other known material when cooled.

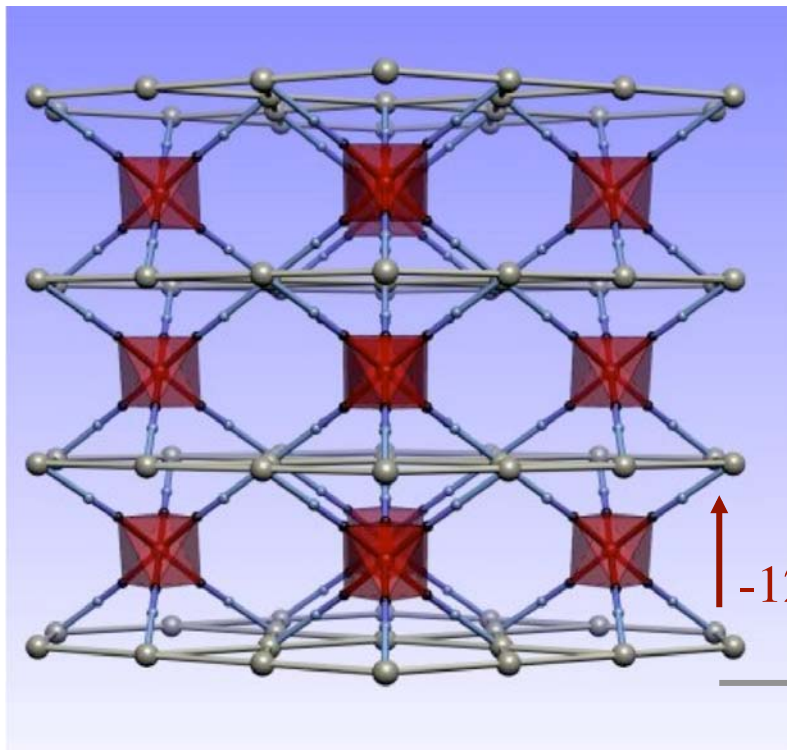

■ In $\text{Ag}_3\text{Co}(\text{CN})_6$ the $\text{Co}(\text{CN})_6$ octahedra (red) sit between layers of Ag atoms. As the bonds between the Ag atoms are relatively weak, the Ag layers can flex easily. When this layer contracts, they push the octahedrons out.

A.L. Goodwin *et al.*, *Science* 319, 794 (2008).

↑ $-120 \times 10^{-6} \text{ K}^{-1}$

→ $140 \times 10^{-6} \text{ K}^{-1}$

The Constant Volume Gas Thermometer

Using the **ideal gas law**: $PV = nRT$

P : pressure in atm ($P=F/A$, 1 atm=101325 N/m²)

V : volume in L

n : number of moles

T : temperature in K

R = Molar gas constant

$$= 0.08214 \text{ L atm mol}^{-1} \text{ K}^{-1}$$

$$= 8.314472 \text{ J mol}^{-1} \text{ K}^{-1}$$

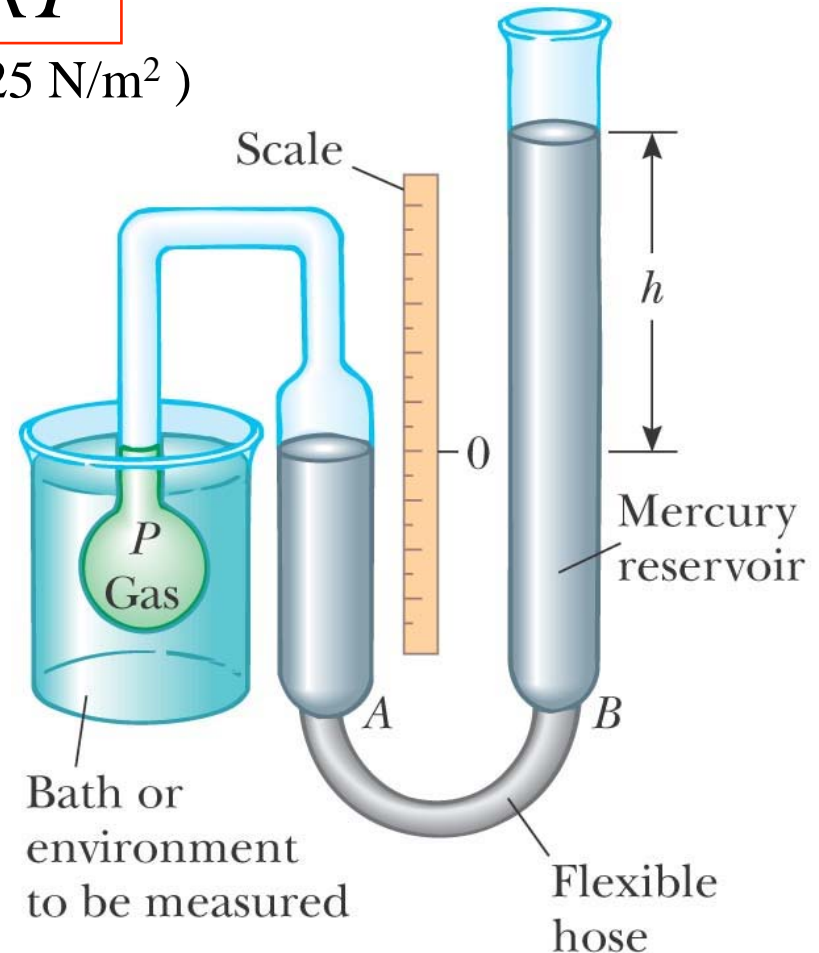
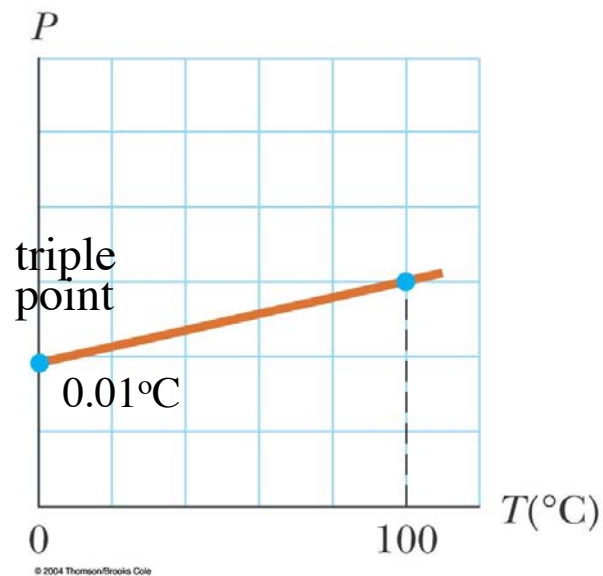

© 2004 Thomson/Brooks Cole

$$P = P_0 - \rho gh$$

$$\rho_{\text{Hg}} = 13,600 \text{ kg m}^{-3}$$

acc. grav.

- 
- The physical change exploited is the variation of pressure of a fixed volume gas as its temperature changes
 - The volume of the gas is kept constant by raising or lowering the reservoir B to keep the mercury level at A constant

If V is constant we get from the ideal gas law $\frac{T_1}{T_2} = \frac{P_1}{P_2}$

If we use the triple point of water ($T = 273.16 \text{ K} = 0.01^\circ\text{C}$) as a reference point

$$T = (273.16\text{K}) \left(\lim_{n \rightarrow 0} \frac{P}{P_{TP}} \right)$$

- The thermometer is calibrated by using a ice water bath and a steam water bath
- The height h (converted to pressure) of the mercury under each situation is recorded

The Fahrenheit Scale

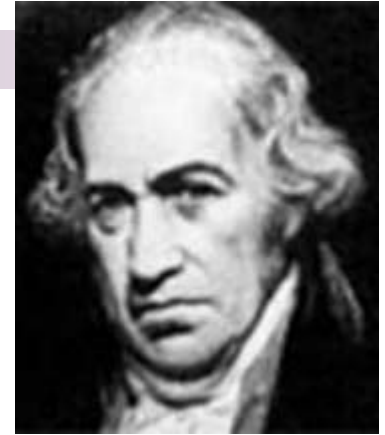

1686-1736

- A common scale in everyday use in the US
- Named after *Daniel Gabriel Fahrenheit*
- Temperature of the ice point is $T_F = 32^\circ\text{F}$
- Temperature of the steam point is $T_F = 212^\circ\text{F}$
- There are 180 divisions (degrees) between the two reference points

$$T_F = \frac{9}{5}T_C + 32^\circ\text{F}$$

$$\begin{aligned} 0^\circ\text{C} &= 32^\circ\text{F} \\ 39^\circ\text{C} &\approx 100^\circ\text{F} \end{aligned}$$

- To compare changes in temperature

$$\Delta T_C = \Delta T_K = \frac{5}{9} \Delta T_F$$